

3GPP TS 38.509 V17.4.0 (2023-06)

Technical Specification

**3rd Generation Partnership Project;
Technical Specification Group Radio Access Network;
5GS;
Special conformance testing functions for User Equipment
(UE)
(Release 17)**



Keywords

5GS, UE, terminal, testing

3GPP

Postal address

3GPP support office address

650 Route des Lucioles - Sophia Antipolis
Valbonne - FRANCE
Tel.: +33 4 92 94 42 00 Fax: +33 4 93 65 47 16

Internet

<http://www.3gpp.org>

Copyright Notification

No part may be reproduced except as authorized by written permission.
The copyright and the foregoing restriction extend to reproduction in all media.

© 2023, 3GPP Organizational Partners (ARIB, ATIS, CCSA, ETSI, TSDSI, TTA, TTC).
All rights reserved.

UMTS™ is a Trade Mark of ETSI registered for the benefit of its members
3GPP™ is a Trade Mark of ETSI registered for the benefit of its Members and of the 3GPP Organizational Partners
LTE™ is a Trade Mark of ETSI registered for the benefit of its Members and of the 3GPP Organizational Partners
GSM® and the GSM logo are registered and owned by the GSM Association

Contents

Foreword.....	6
1 Scope.....	7
2 References.....	7
3 Definitions, symbols and abbreviations.....	8
3.1 Definitions.....	8
3.2 Symbols.....	9
3.3 Abbreviations.....	9
4 UE special conformance test functions overview.....	9
4.1 Requirements for UE support of test functions.....	9
4.2 UE special conformance test functions concept.....	9
5 UE special conformance test functions operation.....	10
5.1 General.....	10
5.2 Activation and deactivation of 5GS test mode bearers (UE test mode procedures).....	11
5.2.1 General.....	11
5.2.2 Activate UE test mode.....	11
5.2.3 Deactivate UE test mode.....	11
5.3 Test loop functions.....	12
5.3.1 General.....	12
5.3.2 Close UE test loop.....	12
5.3.2.0 General.....	12
5.3.2.1 Reception of CLOSE UE TEST LOOP message by the UE.....	13
5.3.2.2 Reception of AT Command +CCUTLE by the UE.....	14
5.3.3 Open UE test loop.....	15
5.3.4 UE functionality when test loop is closed.....	15
5.3.4.1 UE test loop mode A operation.....	15
5.3.4.2 UE test loop mode B operation.....	20
5.3.4.2.1 General.....	20
5.3.4.2.2 UE test loop mode B operation for EN-DC and NGEN-DC.....	21
5.3.4.2.3 UE test loop mode B operation for Standalone NR.....	23
5.3.4.2.4 UE test loop mode B operation for NE-DC.....	25

5.3.4.2A	UE test loop mode C operation.....	27
5.3.4.2A.1	General.....	27
5.3.4.2A.2	Reception of MBS packets.....	30
5.3.4.2A.3	Release of RRC connection.....	31
5.3.4.3	UE test loop mode E operation.....	31
5.3.4.3.0	General.....	31
5.3.4.3.1	Receive or Transmit NR sidelink Communication.....	35
5.4	UE Beamlock test Function (UBF).....	37
5.4.1	General.....	37
5.4.2	Activate Beamlock procedure.....	38
5.4.2.1	Initiation.....	38
5.4.2.2	Reception of ACTIVATE BEAMLOCK message by UE.....	38
5.4.3	Deactivate Beamlock procedure.....	39
5.4.3.1	Initiation.....	39
5.4.3.2	Reception of DEACTIVATE BEAMLOCK message by UE.....	39
5.4.3.3	Release of antenna beamlock by UE.....	39
5.5	UE SS-RSRPB per receiver branch reporting.....	39
5.5.1	General.....	39
5.5.2	Initiation.....	40
5.5.3	Reception of SS-RSRPB REPORT REQUEST message by UE.....	40
5.6	UE Positioning test mode procedures.....	41
5.6.1	Reset UE Positioning Stored Information.....	41
5.6.1.1	General.....	41
5.6.1.2	Initiation.....	41
5.6.1.3	Reception of RESET UE POSITIONING STORED INFORMATION message by UE.....	41
5.6.2	Update UE Location Information.....	42
5.6.2.1	General.....	42
5.6.2.2	Initiation.....	43
5.6.2.3	Reception of UPDATE UE LOCATION INFORMATION message by UE.....	43
5.6.3	UTC time reset.....	43
5.7	NSSAI delete test function.....	43
5.7.1	General.....	43
5.8	Set UAI test function.....	44
5.8.1	General.....	44
5.8.2	Initiation.....	45

5.9	NR Sidelink Packet Counter reporting procedure.....	45
5.9.1	Request NR Sidelink Packet Counter value.....	45
5.9.1.1	General.....	46
5.9.1.2	Initiation.....	46
5.9.1.3	Reception of UE TEST LOOP NR SIDELINK COUNTER REQUEST by the UE.....	46
5.9.1.4	Reception of AT Command +CUSPCREQ by the UE.....	46
5.10	Set UL Message test function.....	47
5.10.1	General.....	47
5.11	UE Power Limit Function (UPLF).....	47
5.11.1	General.....	47
5.11.2	Activate Power Limit Procedure.....	48
5.11.2.1	Initiation.....	48
5.11.2.2	Reception of ACTIVATE POWER LIMIT REQUEST by UE.....	48
5.11.3	Deactivate Power Limit Procedure.....	49
5.11.3.1	Initiation.....	49
5.11.3.2	Reception of DEACTIVATE POWER LIMIT REQUEST message by UE.....	49
5.11.3.3	Removal of power limits by UE.....	49
5.12	MBMS Packet Counter reporting procedure.....	49
5.12.1	Request MBMS Packet Counter value.....	49
5.13	Set MUSIM UAI test function.....	49
5.13.1	General.....	49
5.13.2	Initiation.....	50
6	Test Mode Control message definitions.....	50
6.1	General.....	50
6.2	Test mode messages.....	51
6.2.1	ACTIVATE TEST MODE.....	51
6.2.2	ACTIVATE TEST MODE COMPLETE.....	51
6.2.3	DEACTIVATE TEST MODE.....	51
6.2.4	DEACTIVATE TEST MODE COMPLETE.....	51
6.3	Test loop messages.....	51
6.3.1	CLOSE UE TEST LOOP.....	51
6.3.2	CLOSE UE TEST LOOP COMPLETE.....	52
6.3.3	OPEN UE TEST LOOP.....	52
6.3.4	OPEN UE TEST LOOP COMPLETE.....	52

6.3.5	Void.....	53
6.3.6	Void.....	53
6.4	Beamlock messages.....	53
6.4.1	ACTIVATE BEAMLOCK.....	53
6.4.2	ACTIVATE BEAMLOCK COMPLETE.....	53
6.4.3	DEACTIVATE BEAMLOCK.....	54
6.4.4	DEACTIVATE BEAMLOCK COMPLETE.....	54
6.5	UE SS-RSRP per receiver branch reporting messages.....	54
6.5.1	SS-RSRPB REPORT REQUEST.....	54
6.5.2	SS-RSRPB REPORT RESPONSE.....	55
6.6	UE Positioning messages.....	55
6.6.1	RESET UE POSITIONING STORED INFORMATION.....	55
6.6.2	UPDATE UE LOCATION INFORMATION.....	56
6.7	NSSAI delete messages.....	56
6.7.1	NSSAI DELETE REQUEST.....	56
6.7.2	NSSAI DELETE RESPONSE.....	58
6.8	SET UAI REQUEST.....	58
6.8.1	SET UAI REQUEST.....	58
6.8.2	SET UAI RESPONSE.....	59
6.9	NR SIDELINK PACKET COUNTER reporting messages.....	59
6.9.1	UE TEST LOOP NR SIDELINK PACKET COUNTER REQUEST.....	59
6.9.2	UE TEST LOOP NR SIDELINK PACKET COUNTER RESPONSE.....	59
6.10	SET UL MESSAGE.....	61
6.10.1	SET UL MESSAGE REQUEST.....	61
6.10.2	SET UL MESSAGE RESPONSE.....	61
6.11	Power Limit messages.....	61
6.11.1	ACTIVATE POWER LIMIT REQUEST.....	61
6.11.2	ACTIVATE POWER LIMIT RESPONSE.....	62
6.11.3	DEACTIVATE POWER LIMIT REQUEST.....	63
6.11.4	DEACTIVATE POWER LIMIT RESPONSE.....	63
6.12	UE TEST LOOP MODE C MBMS PACKET COUNTER reporting messages.....	63
6.12.1	UE TEST LOOP MODE C MBMS PACKET COUNTER REQUEST.....	63
6.12.2	UE TEST LOOP MODE C MBMS PACKET COUNTER RESPONSE.....	63
6.13	SET MUSIM UAI REQUEST.....	64
6.13.1	SET MUSIM UAI REQUEST.....	64

6.13.2	SET MUSIM UAI RESPONSE.....	66
7	Variables, constants and timers.....	66
7.1	State variables.....	66
7.2	Constants.....	66
7.3	Timers.....	66
7.4	Configurable parameters.....	66
8	Electrical Man Machine Interface (EMMI).....	67
Annex A (normative): Pre-defined message containers used for testing.....		68
Annex B (informative): Change history.....		72

Foreword

This Technical Specification has been produced by the 3rd Generation Partnership Project (3GPP).

The contents of the present document are subject to continuing work within the TSG and may change following formal TSG approval. Should the TSG modify the contents of the present document, it will be re-released by the TSG with an identifying change of release date and an increase in version number as follows:

Version x.y.z

where:

- x the first digit:
 - 1 presented to TSG for information;
 - 2 presented to TSG for approval;
 - 3 or greater indicates TSG approved document under change control.
- y the second digit is incremented for all changes of substance, i.e. technical enhancements, corrections, updates, etc.
- z the third digit is incremented when editorial only changes have been incorporated in the document.

1 Scope

The present document defines for User Equipment (UE) those special functions and their activation/deactivation methods that are required in the UE for conformance testing purposes when the UE is connected to the 5G System (5GS) via its radio interface(s).

The document also describes the operation of these special functions when the 5GS capable UEs are connected via a non-5GS system e.g. E-UTRA FDD or TDD system.

Depending on the 5GS system's architecture some relevant for the UE for conformance testing special functions may be defined in TS 36.509 [6].

2 References

The following documents contain provisions which, through reference in this text, constitute provisions of the present document.

References are either specific (identified by date of publication, edition number, version number, etc.) or non-specific.

- For a specific reference, subsequent revisions do not apply.
- For a non-specific reference, the latest version applies. In the case of a reference to a 3GPP document (including a GSM document), a non-specific reference implicitly refers to the latest version of that document *in the same Release as the present document* unless the context in which the reference is made suggests a different Release is relevant (information on the applicable release in a particular context can be found in e.g. test case title, description or applicability, message description or content).

- [1] 3GPP TR 21.905: "Vocabulary for 3GPP Specifications".
- [2] 3GPP TS 38.508-1: "5GS; User Equipment (UE) conformance specification; Part 1: Common test environment".
- [3] 3GPP TS 38.523-1: "5GS; User Equipment (UE) conformance specification; Part 1: Protocol".
- [4] 3GPP TS 38.523-3: "5GS; User Equipment (UE) conformance specification; Part 3: Protocol Test Suites".
- [5] 3GPP TS 38.522: "NR; User Equipment (UE) conformance specification; Applicability of RF and RRM test cases".
- [6] 3GPP TS 36.509: "Evolved Universal Terrestrial Radio Access (E-UTRA) and Evolved Packet Core (EPC); Special conformance testing functions for User Equipment (UE)".
- [7] 3GPP TS 24.007: "Mobile radio interface signalling layer 3; General Aspects".
- [8] 3GPP TS 34.109: "Terminal logical test interface; Special conformance testing functions".
- [9] 3GPP TS 44.014: "Individual equipment type requirements and interworking; Special conformance testing functions".
- [10] 3GPP TS 36.331: "Evolved Universal Terrestrial Radio Access (EUTRA) Radio Resource Control (RRC) Protocol Specification".
- [11] 3GPP TS 38.331: "NR Radio Resource Control (RRC) protocol specification".
- [12] 3GPP TS 38.521-1: "NR; User Equipment (UE) conformance specification; Radio transmission and reception; Part 1: Range 1 Standalone".
- [13] 3GPP TS 38.521-2: "NR; User Equipment (UE) conformance specification; Radio transmission and reception; Part 2: Range 2 Standalone".

- [14] 3GPP TS 38.521-3: "NR; User Equipment (UE) conformance specification; Radio transmission and reception; Part 3: Range 1 and Range 2 Interworking operation with other radios".
- [15] 3GPP TS 38.521-4: "NR; User Equipment conformance specification; Radio transmission and reception; Part 4: Performance".
- [16] 3GPP TS 38.533: NR; "User Equipment (UE) conformance specification; Radio resource management".
- [17] 3GPP TS 24.301: "Non-Access-Stratum (NAS) protocol for Evolved Packet System (EPS); Stage 3".
- [18] 3GPP TS 36.323: "Evolved Universal Terrestrial Radio Access (E-UTRA); Packet Data Convergence Protocol (PDCP) specification".
- [19] 3GPP TS 38.323: "NR; Packet Data Convergence Protocol (PDCP) specification".
- [20] 3GPP TS 38.306: "NR; User Equipment (UE) radio access capabilities".
- [21] 3GPP TS 24.501: "Non-Access-Stratum (NAS) protocol for 5G System (5GS); Stage 3".
- [22] 3GPP TS 38.215: "NR; Physical Layer Measurements".
- [23] 3GPP TS 38.321: "NR; Medium Access Control (MAC) protocol specification".
- [24] 3GPP TS 37.355: "LTE Positioning Protocol (LPP)".
- [25] 3GPP TS 38.211: "NR; Physical channels and modulation".
- [26] 3GPP TS 24.587: " Vehicle-to-Everything (V2X) services in 5G System (5GS), Stage 3".

3 Definitions, symbols and abbreviations

3.1 Definitions

For the purposes of the present document, the terms and definitions given in 3GPP TR 21.905 [1] and the following apply. A term defined in the present document takes precedence over the definition of the same term, if any, in 3GPP TR 21.905 [1].

Frequency Range 2 (FR2): The frequency ranges in which NR can operate being in the range of 24250 MHz - 52600 MHz.

Logical Test Interface: interface which provides the logical service to interwork and to communicate between UE and System Simulator during the test of a UE

SS (System Simulator): test system (or equipment) that drives the test process with UE, like 5G System simulator

TMC (Test Mode Control): UE protocol entity used by the SS to control the UE specific testing functions

NOTE: In other Special conformance testing functions for User Equipment (UE) 3GPP specifications e.g. 36.509 [6], the term Test Control (TC) is used for describing the same UE entity. The different names do not preclude the implementation of a single entity to handle all the functionality in a UE supporting different 3GPP technologies.

UE (User Equipment): user equipment as defined in [1] that is under test

3.2 Symbols

No specific symbols apply for the purposes of the present document.

3.3 Abbreviations

For the purposes of the present document, the abbreviations given in 3GPP TR 21.905 [1] and the following apply. An abbreviation defined in the present document takes precedence over the definition of the same abbreviation, if any, in 3GPP TR 21.905 [1].

EMMI	Electrical Man Machine Interface
FFS	For further Study
FR2	Frequency Range 2
LB	Loop Back
MTC	Main Test Component
NSSAI	Network Slice Selection Assistance Information
SS	System Simulator
TMC	Test Mode Control

4 UE special conformance test functions overview

4.1 Requirements for UE support of test functions

The UE special conformance test functions are required for the support of 5GS conformance testing. They form a part of the core requirements and thus have a direct impact on the design of the UE. The use of the word "mandatory" in the present specification shall be understood as a particular requirement being mandatory for performing UE conformance testing.

NOTE: While the importance of conformance testing should not be underestimated, and hence is highly recommended, the implementation of facilitation of it is left to the Device implementation.

4.2 UE special conformance test functions concept

The present specification defines the UE special conformance test functions including any relevant procedure and the Test Mode Control (TMC) message contents used for information exchange.

The conformance test methods applied in RF/RRM Conformance Test Specification TS 38.521-1 [12], TS 38.521-2 [13], TS 38.521-3 [14], TS 38.521-4 [15] and TS 38.533 [16], and, the conformance test models used in Protocol Conformance Test Specifications TS 38.523-1 [3] and TS 38.523-3 [4], as well as, common test environment definition and Generic procedures specified in TS 38.508-1 [2] utilise the UE special conformance test functions. Default TMC messages and information element contents utilised in all before mentioned test specifications are specified in TS 38.508-1 [2].

The UE special conformance test functions vary depending on the conformance testing functionality they are designed to support. The following broader groups of UE special conformance test functions can be identified:

- **Test Loop Functions:** Functions which require a loop to be established between the UE and the System Simulator (SS) to allow e.g. DL data packets sent by the SS to be looped back UL by the UE
- **General Test Functions:** Commands send by the SS e.g. to trigger a certain UE behaviour which may be a behaviour determined by 3GPP core spec requirements or such needed to facilitate conformance testing and not being part of any 3GPP core spec requirements, or, to provide to the UE information needed for the conformance testing.

NOTE 1: An example for behaviour needed to facilitate conformance testing and not representing behaviour determined by 3GPP core spec requirements is counting and reporting the number of received data packets thereby providing means to the SS to verify 3GPP core spec requirements.

The utilisation of any UE special conformance test functions shall be considered as putting the UE in a test mode. The duration of the test mode depends on the UE special conformance test function and in most of the cases will be delimited by an activation and a deactivation command. However, in the case of general test functions used e.g. only to provide information relevant for the conformance testing the test mode can be considered as entered as soon as the information is received and exited as soon as the information has been acted upon.

As a common rule the UE special conformance test functions provide access to isolated functions of the UE via the radio interface without introducing new physical interfaces just for the reason of conformance testing. However, in certain cases the usage of AT Commands may be required which will require an external interface e.g. EMMI.

NOTE 2: It should be emphasised that the UE test functions only describe the functional behaviour of the UE with respect to its external interfaces; physical implementation of the UE test function is completely left open to the manufacturer.

Depending on the conformance testing functionality they are designed to support, the UE special conformance test functions may comprise:

- A single DL message (e.g. a test function intended to provide to the UE information needed for the conformance testing)
- A Request/Acknowledgement type of 2 messages exchange, an DL message followed by a UL message, (e.g. a test function intended to request the UE to execute an action which requires acknowledgment that request was received and acted upon)

Furthermore, depending on the conformance test scenarios

- An UE special conformance test function can be used in isolation.

NOTE 3: An example for this is the provision to the UE of location information which can then be used by the UE throughout its "normal" i.e. not test mode functions dependant behaviour.

- Two, or more, UE special conformance test functions may need to be executed in a particular sequence before the target UE behaviour can be assumed.

NOTE 4: An example for this are the Activate UE test mode and Close UE test loop functions. The former needs to be executed first, at a particular moment of time, in order a specific type of test bearer terminated in a particular UE protocol layer to be established. Followed by the latter, executed at different point of time, which will instruct the UE to start looping back the received packets.

- Two, or more, UE special conformance test functions may be executed simultaneously with no particular relation one to another allowing for different test mode functionality to take place at the same time.

NOTE 5: An example for this are the UE Beamlock test function and the test functions needed for test loop mode operation (see NOTE 4). The former may need to be active throughout the entire tests with the latter being active in parts of the test as appropriate. Both being active independently.

For the specification of UE special conformance test functions the present specification may refer to other specifications. In the case when text on the same matter exists in the present specification and in the referred specification, the text in the present specification takes precedence.

5 UE special conformance test functions operation

5.1 General

For consistency with legacy terminology, the present specification uses the terms 'Activate UE test mode' and 'Deactivate UE test mode' for denoting the activation and the deactivation of 5GS test mode bearers procedures respectively. Consequently, 'Activate UE test mode' should not be understood as setting the UE in test mode in general rather, as setting the UE in a mode (i.e. establishing a special type of test bearers) which other special UE conformance testing functions require for proper operation. As this has been mentioned elsewhere in the present specification, not all special UE conformance testing functions require such a setting.

Similarly, the present specification may use the term "UE test loop mode X operation", where X is a chose letter, for denoting operation which does not represent true looping back of data being received rather, it represents what can be called as a "pseudo loop" i.e. providing back information about the received data e.g. the number of the received packets.

5.2 Activation and deactivation of 5GS test mode bearers (UE test mode procedures)

5.2.1 General

The SS performs, where applicable, activation and deactivation of the conformance test functions in the UE by sending Security Protected NAS Layer 3 messages.

The UE test mode procedures are intended for setting the UE into a test mode where the SS can set up test bearers terminated at a particular point in the 5GS protocol stack as specified in the functional block diagram of each UE test loop mode of operation. The following test bearers are defined in the present specification:

- data radio bearers (UE test loop mode A),
- EPS bearers or 5GS QoS flows (UE test loop mode B).
- MBS radio bearers (UE test loop mode C).
- NR PC5 QoS flows (UE test loop mode E).

5.2.2 Activate UE test mode

Same as TS 36.509 [6], subclause 5.3.2 with the following exceptions:

- where E-UTRA is mentioned the same applies for NR;
- where V2X is mentioned the same applies for NR sidelink;
- MTCH data radio bearer is replaced by MBS radio bearer;

the NB-IoT mode is out of the scope of the present specification;

where different UE test loop modes are mentioned only those applicable to 5GS should be taken into account (see subclause 5.3.4 for the applicable 5GS UE test loop modes).

5.2.3 Deactivate UE test mode

Same as TS 36.509 [6], subclause 5.3.3 with the following exceptions

- where E-UTRA is mentioned the same applies for NR;
- where V2X is mentioned the same applies for NR sidelink;
- the NB-IoT mode is out of the scope of the present specification;
- where different UE test loop modes are mentioned only those applicable to 5GS should be taken into account (see subclause 5.3.4 for the applicable 5GS UE test loop modes).

Apart from sending the appropriate deactivation command to the UE the functions shall be deactivated by:

switching off the UE; or

by removing the USIM.

5.3 Test loop functions

5.3.1 General

Before a loop functionality can be exercised, the test loop needs to be closed; this is to be understood as the UE being instructed to start looping back received data packets. When looping back received data packets is not any longer required the loop should be re-opened; opening of a loop does not change the type of bearer being established by the UE test mode activation function (subclause 5.2.2).

To limit the number of special test functions, the concept of closing and opening a loop is also used as instruction to the UE to initiate/terminate other actions. An example of this is counting the received packets and reporting the number of received packets back to the SS; in the context of this utilisation closing a loop is to be understood as the UE being instructed to start counting the packets, whereas opening a loop should be understood as stop counting the packets. Other utilisation of the closing/opening a "test loop" test functionality can be specified if appropriate.

The UE test loop functions for 5GS are intended for:

- NR receiver and transmitter testing to disable application data transfer in downlink and uplink during SS UE measurements.
- NR layer 2 (MAC, RLC, PDCP, SDAP) and data radio bearer testing to generate data transfer in downlink and uplink.
- NR layer 2 (MAC, RLC, PDCP, SDAP) and sidelink data radio bearer testing to generate data transfer in sidelink.
- NR layer 2 (MAC, RLC, PDCP) and MBS radio bearer testing.
- 5GC and NR layer 3 testing to verify data transfer continuation over RRC and 5GC procedures.
- 5GC and NR layer 3 testing to verify data transfer over PC5 interface.
- 5GC NAS user-plane testing to verify uplink QoS flow descriptions handling.
- PC5-U testing to verify sidelink PC5 QoS flow descriptions handling.

5.3.2 Close UE test loop

5.3.2.0 General

Same as TS 36.509 [6], subclause 5.4.2 with the following exceptions:

- where E-UTRA is mentioned the same applies for NR;
- where V2X is mentioned the same applies for NR sidelink;
- the NB-IoT mode is out of the scope of the present specification
- where different UE test loop modes are mentioned only those applicable to 5GS should be taken into account (see subclause 5.3.4 for the applicable 5GS UE test loop modes).
- where EPS bearers are mentioned the same applies for 5GS QoS flows;
- where MTCH data radio bearer is replaced by MBS radio bearer;
- UE supported minimum buffer size for MR-DC and NR shall match the required total layer 2 buffer size as specified in TS 38.306 [20], clause 4.1.4.
- Subclause 5.4.2.3 in TS 36.509 [6] is replaced by 5.3.2.1 in current specification; and
- Subclause 5.4.2.4 in TS 36.509 [6] is replaced by 5.3.2.2 in current specification.

5.3.2.1 Reception of CLOSE UE TEST LOOP message by the UE

Same as TS 36.509 [6], subclause 5.4.2.3 with the following exceptions:

...

- 1> else if UE test loop mode C has been selected;
 - 2> if no MBS radio bearer is established or if the UE test mode is not active; or
 - 2> if UE test loop mode A or UE test loop mode B operation is already closed on one or more data radio bearers; or
 - 2> if TEST_LOOP_MODE_C_ACTIVE = TRUE or TEST_LOOP_MODE_D_ACTIVE = TRUE or TEST_LOOP_MODE_E_ACTIVE = TRUE or TEST_LOOP_MODE_F_ACTIVE = TRUE or TEST_LOOP_MODE_G_ACTIVE = TRUE or TEST_LOOP_MODE_H_ACTIVE = TRUE or TEST_LOOP_MODE_I_ACTIVE = TRUE:
 - 3> the UE behaviour is unspecified.
 - 2> otherwise:
 - 3> set TEST_LOOP_MODE_C_ACTIVE to TRUE
 - 3> set state variable MBS_PACKET_COUNTER to zero;
 - 3> perform the UE actions for UE Test Loop Mode C operation as specified in subclause 5.3.4.2A and
 - 3> send CLOSE UE TEST LOOP COMPLETE message (the loopback shall be operational prior to the sending of the acknowledgement).
- 1> else if UE test loop mode E has been selected;
 - 2> if UE test loop mode A or UE test loop mode B operation is already closed on one or more data radio bearers; or
 - 2> if TEST_LOOP_MODE_C_ACTIVE = TRUE or TEST_LOOP_MODE_D_ACTIVE = TRUE or TEST_LOOP_MODE_E_ACTIVE = TRUE or TEST_LOOP_MODE_F_ACTIVE = TRUE or TEST_LOOP_MODE_G_ACTIVE = TRUE or TEST_LOOP_MODE_H_ACTIVE = TRUE or TEST_LOOP_MODE_I_ACTIVE = TRUE; or
 - 2> if the UE is unable to read the pre-configured parameters for NR sidelink Communication from the USIM; or
 - 2> when test loop mode E is utilised in NR sidelink out-of-coverage scenarios:
 - 3> the UE behaviour is unspecified.
 - 2> otherwise:
 - 3> set TEST_LOOP_MODE_E_ACTIVE to TRUE
 - 3> if the E0 bit in Communication Transmit or Receive parameter in UE test loop mode E setup IE is set as zero;
 - 4> set TEST_LOOP_MODE_E_TRIGGER to RECEIVE
 - 4> set state variable PROSE_COMMUNICATION_MONITOR_N to the number of entities in the list of Group Destination IDs to individually monitor included in the UE test loop mode E setup IE;
 - 4> if PROSE_COMMUNICATION_MONITOR_N is greater than MAX_ModeE_Monitor_Entities:
 - 5> the UE behaviour is unspecified.
 - 4> for SL_ID = 0...(PROSE_COMMUNICATION_MONITOR_N-1):

- 5> set state variable PROSE_COMMUNICATION_DEST_ID(SL_ID) to the parameter Group Destination ID #(SL_ID) to monitor of the UE test loop mode E setup IE;
- 5> set state variable STCH_PACKET_COUNTER(SL_ID) to zero;
- 5> set state variable PSCCH_PACKET_COUNTER(SL_ID) to zero;
- 5> set state variable PSSCH_PACKET_COUNTER(SL_ID) to zero;
- 4> set state variable STCH_PACKET_COUNTER(PROSE_COMMUNICATION_MONITOR_N) to zero;
- 4> set state variable PSCCH_PACKET_COUNTER(PROSE_COMMUNICATION_MONITOR_N) to zero;
- 4> set state variable PSSCH_PACKET_COUNTER(PROSE_COMMUNICATION_MONITOR_N) to zero;
- 4> perform the UE actions for UE Test Loop Mode E operation as specified in subclause 5.3.4.3.1;
- 3> if the E0 bit in Communication Transmit or Receive parameter in UE test loop mode E setup IE is set as one;
 - 4> if the E1 bit in Communication Transmit or Receive parameter in UE test loop mode E setup IE is set as zero;
 - 5> set TEST_LOOP_MODE_E_TRIGGER to TRANSMIT;
 - 4> else
 - 5> set TEST_LOOP_MODE_E_TRIGGER to TRANSMIT_SL_MIMO;
 - 4> perform the UE actions for UE Test Loop Mode E operation as specified in subclause 5.3.4.3.1;
- 3> send CLOSE UE TEST LOOP COMPLETE message (the loopback shall be operational prior to the sending of the acknowledgement).

5.3.2.2 Reception of AT Command +CCUTLE by the UE

Upon receiving the AT Command

+CCUTLE=<status=0>[,<direction>[,<format>,<length>,<monitor_list>,<sl_mimo>]] the UE shall:

- 1> if UE test loop mode E has been selected;
 - 2> if TEST_LOOP_MODE_E_ACTIVE = TRUE; or
 - 2> if the UE is unable to read the pre-configured parameters for NR sidelink Communication from the USIM:
 - 3> the UE behaviour is unspecified.
 - 2> otherwise:
 - 3> set TEST_LOOP_MODE_E_ACTIVE to TRUE
 - 3> if the <direction> parameter in +CCUTLE set command is set as zero;
 - 4> set TEST_LOOP_MODE_E_TRIGGER to RECEIVE
 - 4> if the <format> parameter in +CCUTLE set command is set as 1
 - 5> set state variable PROSE_COMMUNICATION_MONITOR_N to the number of entities in the list of Destination Layer-2 IDs to individually monitor included in the <monitor_list> parameter of +CCUTLE set command;
 - 5> if PROSE_COMMUNICATION_MONITOR_N is greater than MAX_ModeE_Monitor_Entities:

- 6> the UE behaviour is unspecified.
- 5> for SL_ID = 0...(PROSE_COMMUNICATION_MONITOR_N-1):
 - 6> set state variable PROSE_COMMUNICATION_DEST_ID(SL_ID) to the parameter Destination Layer-2 ID #(SL_ID) to monitor in the +CCUTLE set command;
 - 6> set state variable STCH_PACKET_COUNTER(SL_ID) to zero;
 - 6> set state variable PSCCH_PACKET_COUNTER(SL_ID) to zero;
 - 6> set state variable PSSCH_PACKET_COUNTER(SL_ID) to zero;
- 5> set state variable STCH_PACKET_COUNTER(PROSE_COMMUNICATION_MONITOR_N) to zero;
- 5> set state variable PSCCH_PACKET_COUNTER(PROSE_COMMUNICATION_MONITOR_N) to zero;
- 5> set state variable PSSCH_PACKET_COUNTER(PROSE_COMMUNICATION_MONITOR_N) to zero;
- 5> perform the UE actions for UE Test Loop Mode E operation as specified in subclause 5.3.4.3.1;
- 4> else
 - 5> the UE behaviour is unspecified.
- 3> if the <direction> parameter in +CCUTLE set command is set as one;
 - 4> if the <sl_mimo> parameter in UE test loop mode E setup IE is set as zero
 - 5> set TEST_LOOP_MODE_E_TRIGGER to TRANSMIT
 - 4> else
 - 5> set TEST_LOOP_MODE_E_TRIGGER to TRANSMIT_SL_MIMO;
 - 4> perform the UE actions for UE Test Loop Mode E operation as specified in subclause 5.3.4.3.1;
- 1> else;
 - 2> the UE behaviour is unspecified.

5.3.3 Open UE test loop

Same as TS 36.509 [6], subclause 5.4.5 with the exceptions:

- where E-UTRA is mentioned the same applies for NR;
- where V2X is mentioned the same applies for NR sidelink;
- the NB-IoT mode is out of the scope of the present specification;
- where different UE test loop modes are mentioned only those applicable to 5GS should be taken into account (see subclause 5.3.4 for the applicable 5GS UE test loop modes).

5.3.4 UE functionality when test loop is closed

5.3.4.1 UE test loop mode A operation

UE test loop mode A provides loopback of PDCP SDUs for bi-directional data radio bearers while UE is operating in NR. The downlink PDCP SDUs received by the UE on each bi-directional data radio bearer are returned on the same

radio bearer regardless of the PDCP SDU contents and of the QoS flow descriptions of the associated QoS Flow as specified in TS 24.501 [21].

Figures 5.3.4.1-1 and 5.3.4.1-2 show functional block diagrams of UE test loop function for the TMC entity and UE test loop mode A for the case when EN-DC or NGEN-DC with a MCG bearer and a SCG bearer is configured and for the case EN-DC or NGEN-DC with a MCG and a split bearer is configured.

Figures 5.3.4.1-3 shows functional block diagrams of UE test loop function for the TMC entity and UE test loop mode A for the case when standalone NR is configured Header compression / decompression block in NR PDCP covers ROHC and EHC protocols as described in TS 38.323 [19] clause 4.2.2.

Figures 5.3.4.1-4 and 5.3.4.1-5 show functional block diagrams of UE test loop function for the TMC entity and UE test loop mode A for the case when NE-DC with a MCG bearer and a SCG bearer is configured and for the case NE-DC with a MCG and a split bearer is configured.

NOTE 1: The number and the order of RB LB Entities in the functional block diagrams are provided for illustration only. No specific order or numbering is precluded.

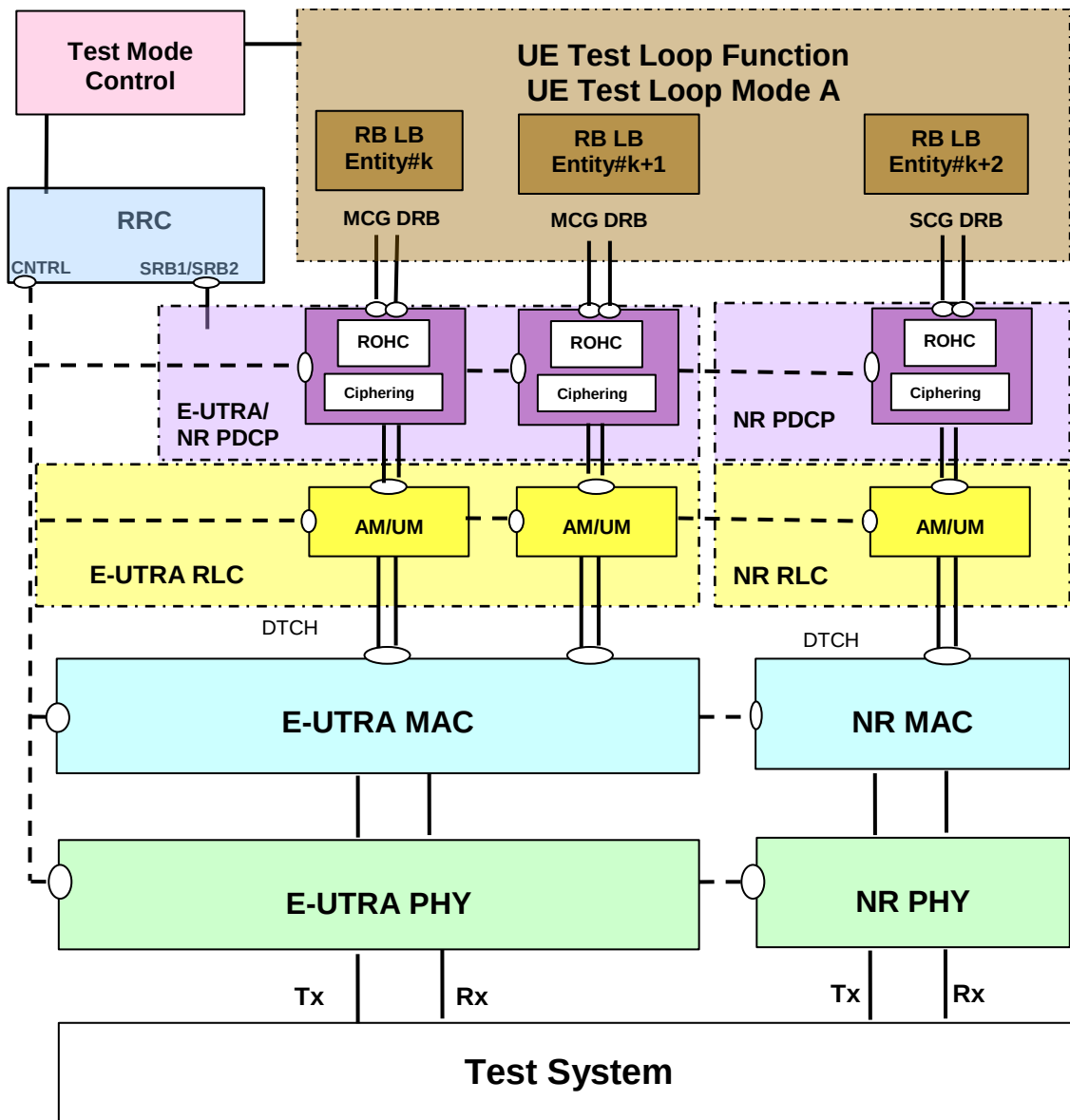

Figure 5.3.4.1-1: Model for Test Mode Control and UE Test Loop Mode A on UE side when EN-DC or NGEN-DC with MCG bearer and SCG bearer is configured

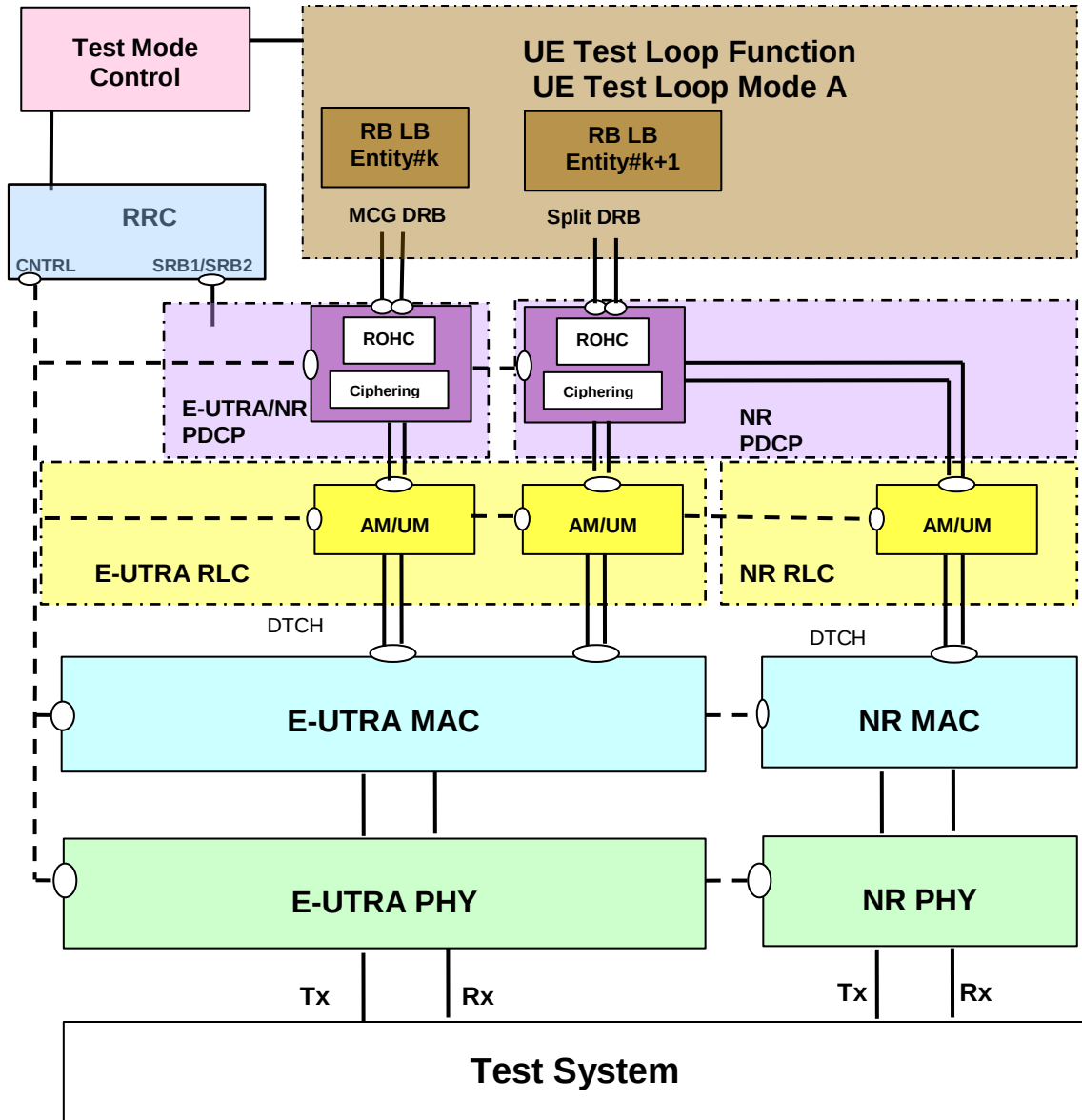

Figure 5.3.4.1-2: Model for Test Mode Control and UE Test Loop Mode A on UE side when EN-DC or NGEN-DC with MCG and split bearer configured

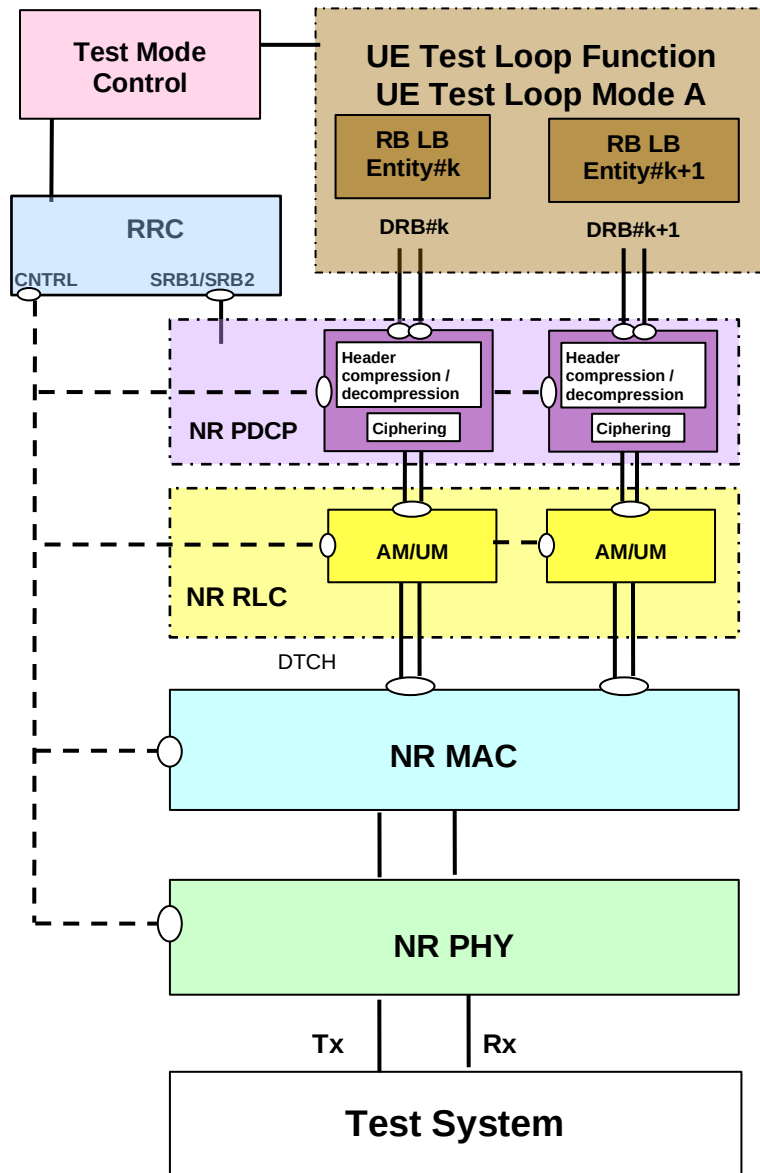

Figure 5.3.4.1-3: Model for Test Mode Control and UE Test Loop Mode A on UE side when standalone NR is configured

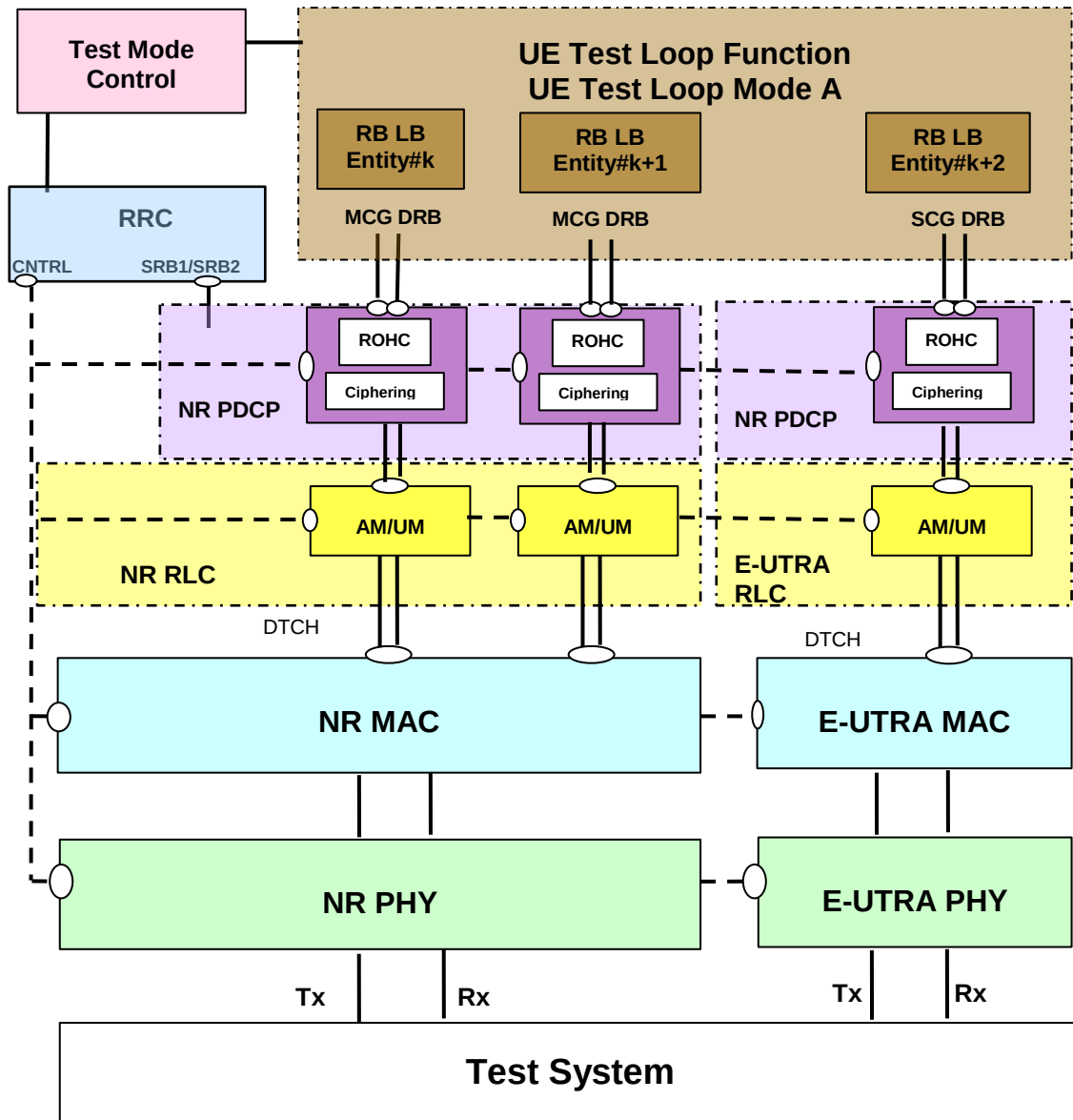

Figure 5.3.4.1-4: Model for Test Mode Control and UE Test Loop Mode A on UE side when NE-DC with MCG and SCG bearers configured

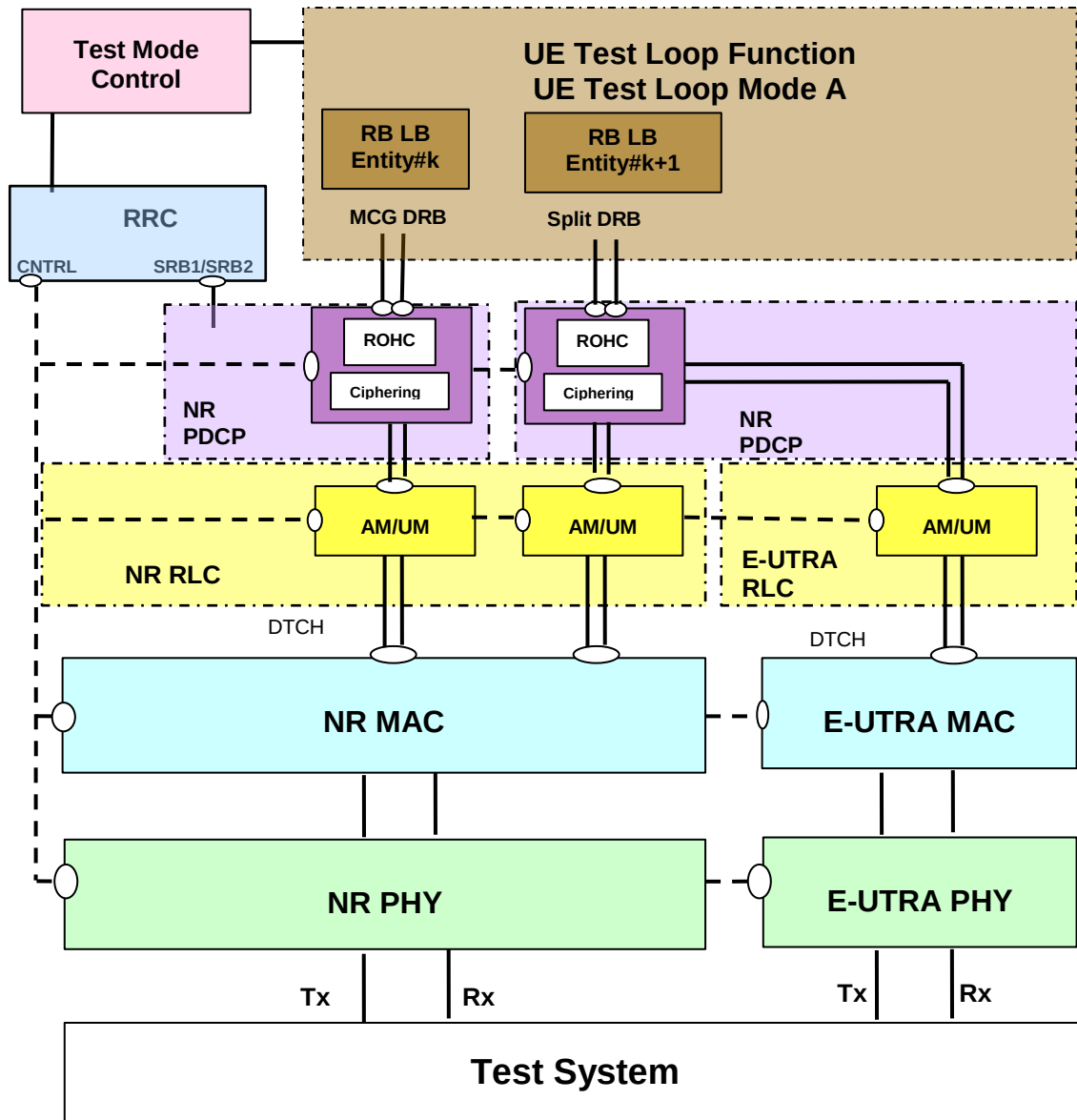

Figure 5.3.4.1-5: Model for Test Mode Control and UE Test Loop Mode A on UE side when NE-DC with MCG and split bearers configured

UE test loop mode A is mandatory to all 5GS UEs.

Prior to closing the UE test loop mode A, thereby requesting the UE to start looping back the received data packets, at least one 5GS test mode bi-directional data radio bearer shall have been established between SS and UE. This implies that before the procedure for establishing the bi-directional data radio bearer takes place the SS needs to activate the UE test mode as specified in subclause 5.2.2.

The 5GS UE test loop mode A operation is the same as the one described in TS 36.509 [6], subclause 5.4.3 with the exception where E-UTRA is mentioned the same applies for NR, and, the understanding that the NB-IoT mode is out of the scope of the present specification.

5.3.4.2 UE test loop mode B operation

5.3.4.2.1 General

UE test loop mode B is mandatory to all 5GS UEs supporting one or more PDU session establishments.

5.3.4.2.2 UE test loop mode B operation for EN-DC and NGEN-DC

UE test loop mode B provides loopback of PDCP SDUs for bi-directional EPS bearers while UE is operated in NR or E-UTRA modes. When operating in NR or E-UTRA, the downlink PDCP SDUs or SND CP PDUs received by the UE on all bi-directional data radio bearers are returned by the UE on the data radio bearer associated with an QoS Flow with a QoS flow descriptions matching the TCP/UDP/IP protocol information within the PDCP SDU or SND CP SDU as specified in TS 24.501 [21].

NOTE 1: When multiple PDN connections are established (or multiple Primary PDP Contexts are active), it is assumed that different IP addresses are allocated to the UE by the SS on each PDN.

Figures 5.3.4.2.2-1 and 5.3.4.2.2-2 show functional block diagrams of UE test loop function for the TMC entity and UE test loop mode B for the case when EN-DC or NGEN-DC with a MCG bearer and a SCG bearer is configured and for the case EN-DC or NGEN-DC with a MCG and a split bearer is configured.

NOTE 2: The number and the order of RB LB Entities in the UE Test Loop Function in the functional block diagrams are provided for illustration only. No specific order or numbering is precluded.

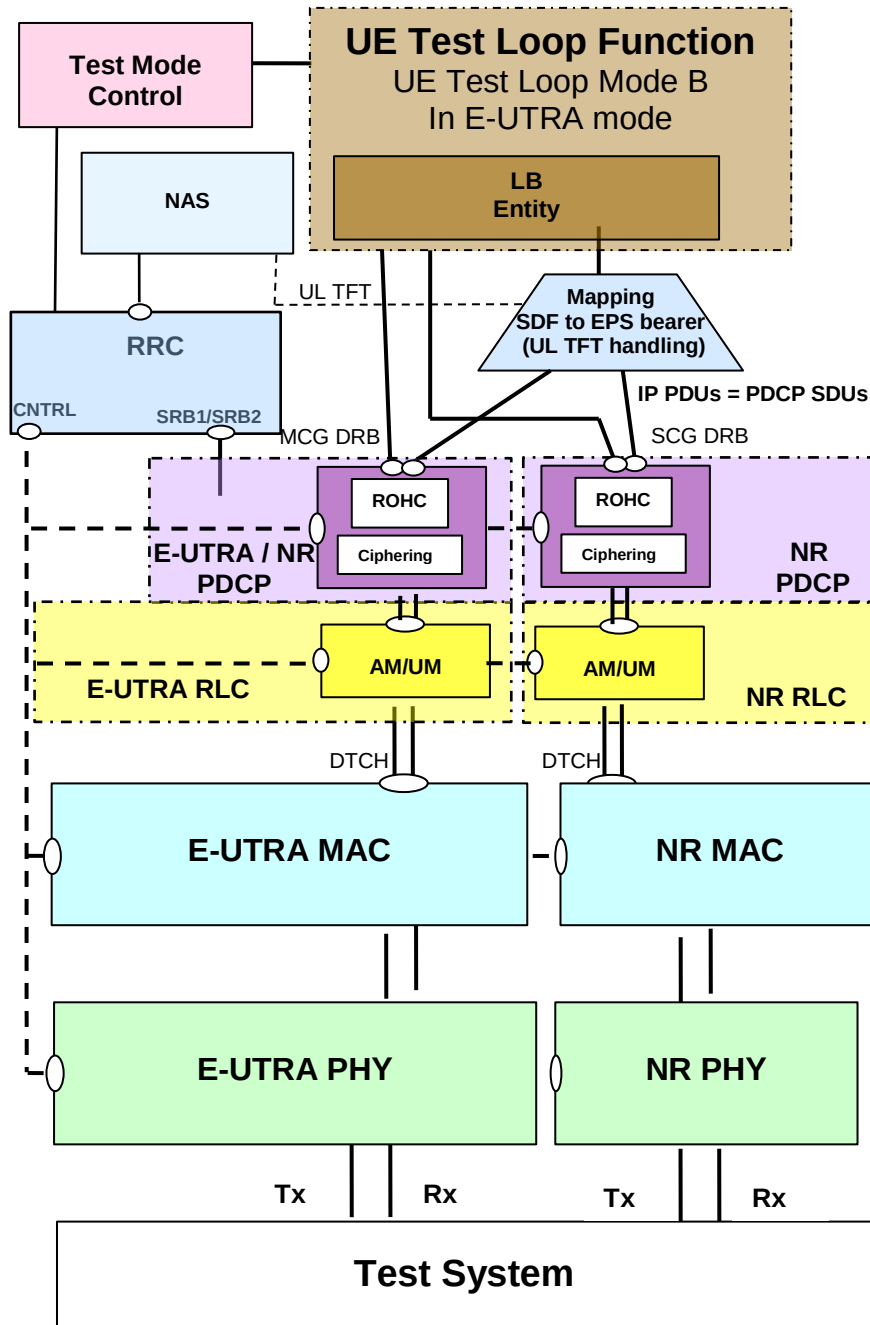

Figure 5.3.4.2.2-1: Model for Test Mode Control and UE Test Loop Mode B on UE side when EN-DC or NGEN-DC with MCG bearer and SCG bearer is configured

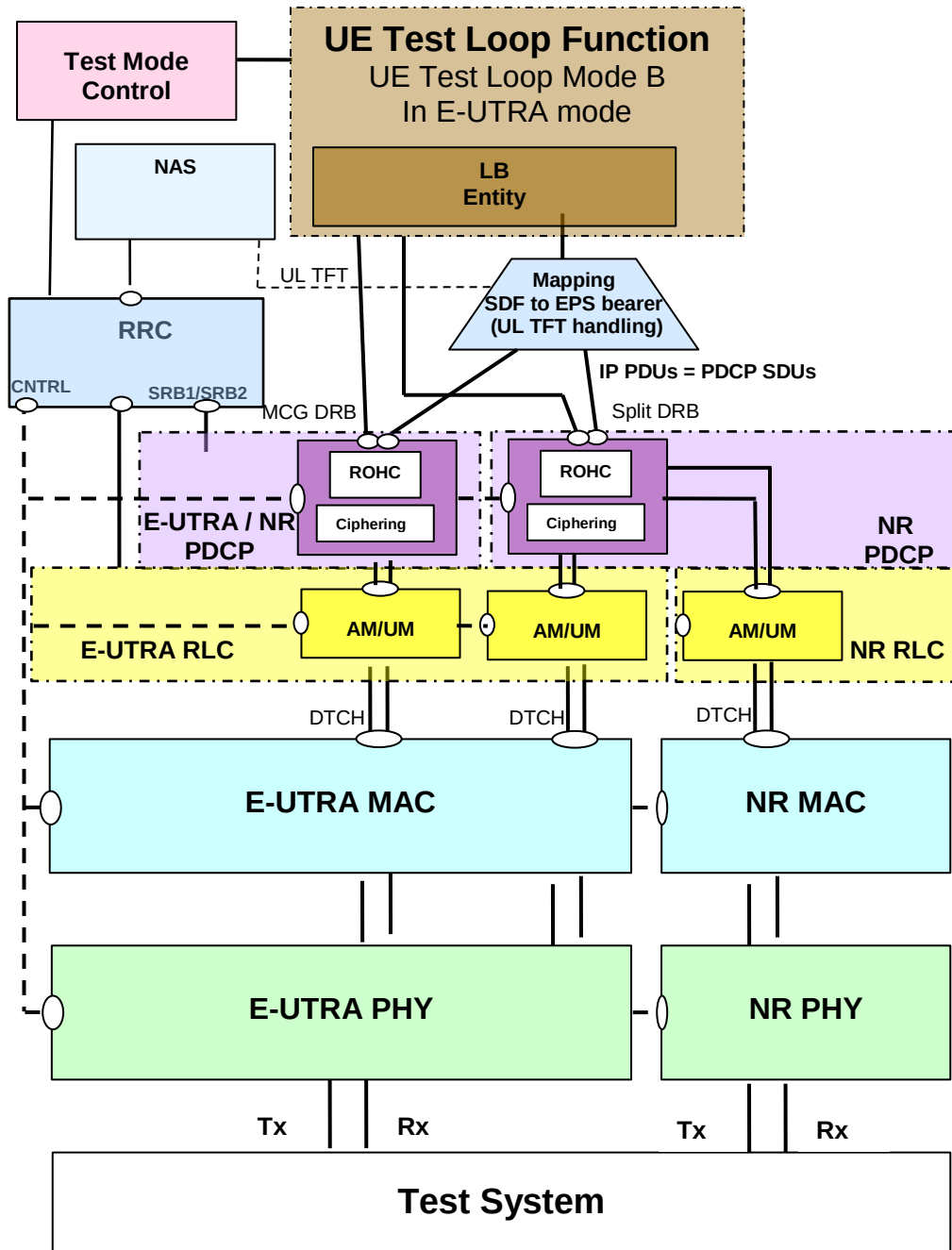

Figure 5.3.4.2.2-2: Model for Test Mode Control and UE Test Loop Mode B on UE side when EN-DC or NGEN-DC with MCG and split bearer configured

5.3.4.2.3 UE test loop mode B operation for Standalone NR

UE test loop mode B provides loopback of SDAP SDUs for bi-directional QoS Flows while UE is operated in standalone NR mode. Prior to closing the UE test loop mode B, thereby requesting the UE to start looping back the received data packets, at least one 5GS test mode bi-directional QoS Flow shall have been established between SS and UE. This implies that before the procedure for establishing the bi-directional QoS Flows takes place the SS needs to activate the UE test mode as specified in subclause 5.2.2

The downlink SDAP SDUs or IP PDU's received by the UE on all bi-directional QoS Flows are returned by the UE without any modification of the IP header to the UL QoS flow descriptions handling SAP for transmission in uplink.

NOTE 1: When multiple PDU sessions are established, it is assumed that different IP addresses are allocated to the UE by the SS on each PDU session.

Figure 5.3.4.2.3-1 shows functional block diagrams of UE test loop function for the TMC entity and UE test loop mode B for the case when standalone NR is configured.

NOTE 2: The number and the order of QoS Flow LB Entities in the UE Test Loop Function in the functional block diagrams are provided for illustration only. No specific order or numbering is precluded.

The 5GS UE test loop mode B operation is the same as the one described in TS 36.509 [6], subclause 5.4.4 with the exception where E-UTRA is mentioned the same applies for NR, and, where PDCP SDU is mentioned the same applies for SDAP SDU.

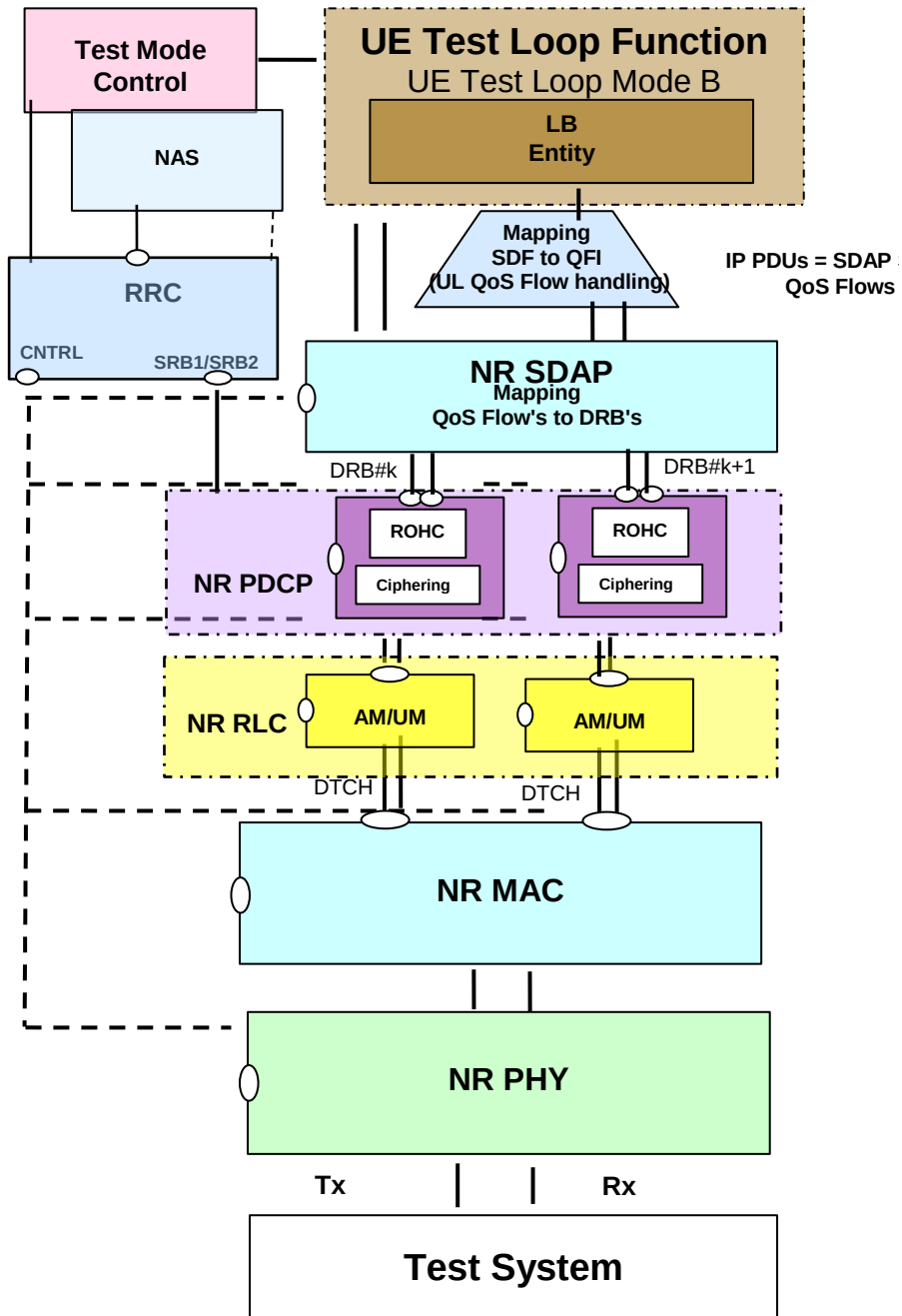

Figure 5.3.4.2.3-1: Model for Test Mode Control and UE Test Loop Mode B on UE side when standalone NR is configured

5.3.4.2.4 UE test loop mode B operation for NE-DC

UE test loop mode B provides loopback of SDAP SDUs for bi-directional QoS Flows while UE is operated in NR or E-UTRA modes. Prior to closing the UE test loop mode B, thereby requesting the UE to start looping back the received data packets, at least one 5GS test mode bi-directional QoS Flow shall have been established between SS and UE. This implies that before the procedure for establishing the bi-directional QoS Flows takes place the SS needs to activate the UE test mode as specified in subclause 5.2.2

The downlink SDAP SDUs or IP PDU's received by the UE on all bi-directional QoS Flows are returned by the UE without any modification of the IP header to the UL QoS flow descriptions handling SAP for transmission in uplink.

NOTE 1: When multiple PDU sessions are established, it is assumed that different IP addresses are allocated to the UE by the SS on each PDU session.

Figure 5.3.4.2.4-1 and 5.3.4.2.4-2 show functional block diagrams of UE test loop function for the TMC entity and UE test loop mode B for the case when NE-DC with a MCG and a SCG bearer is configured and for the case NE-DC with a MCG and a split bearer is configured.

NOTE 2: The number and the order of QoS Flow LB Entities in the UE Test Loop Function in the functional block diagrams are provided for illustration only. No specific order or numbering is precluded.

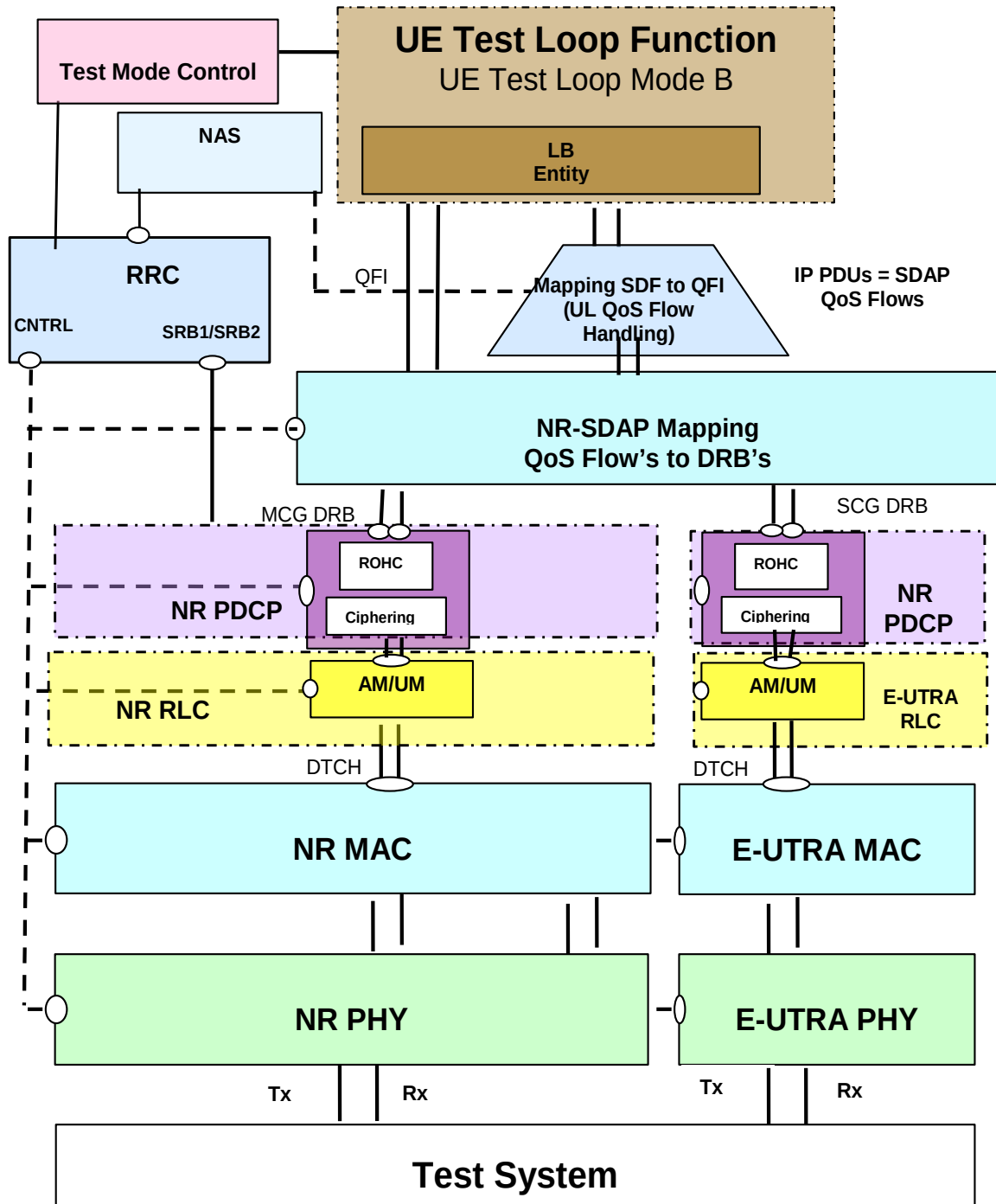

Figure 5.3.4.2.4-1: Model for Test Mode Control and UE Test Loop Mode B on UE side when NE-DC with MCG bearer and SCG bearers configured

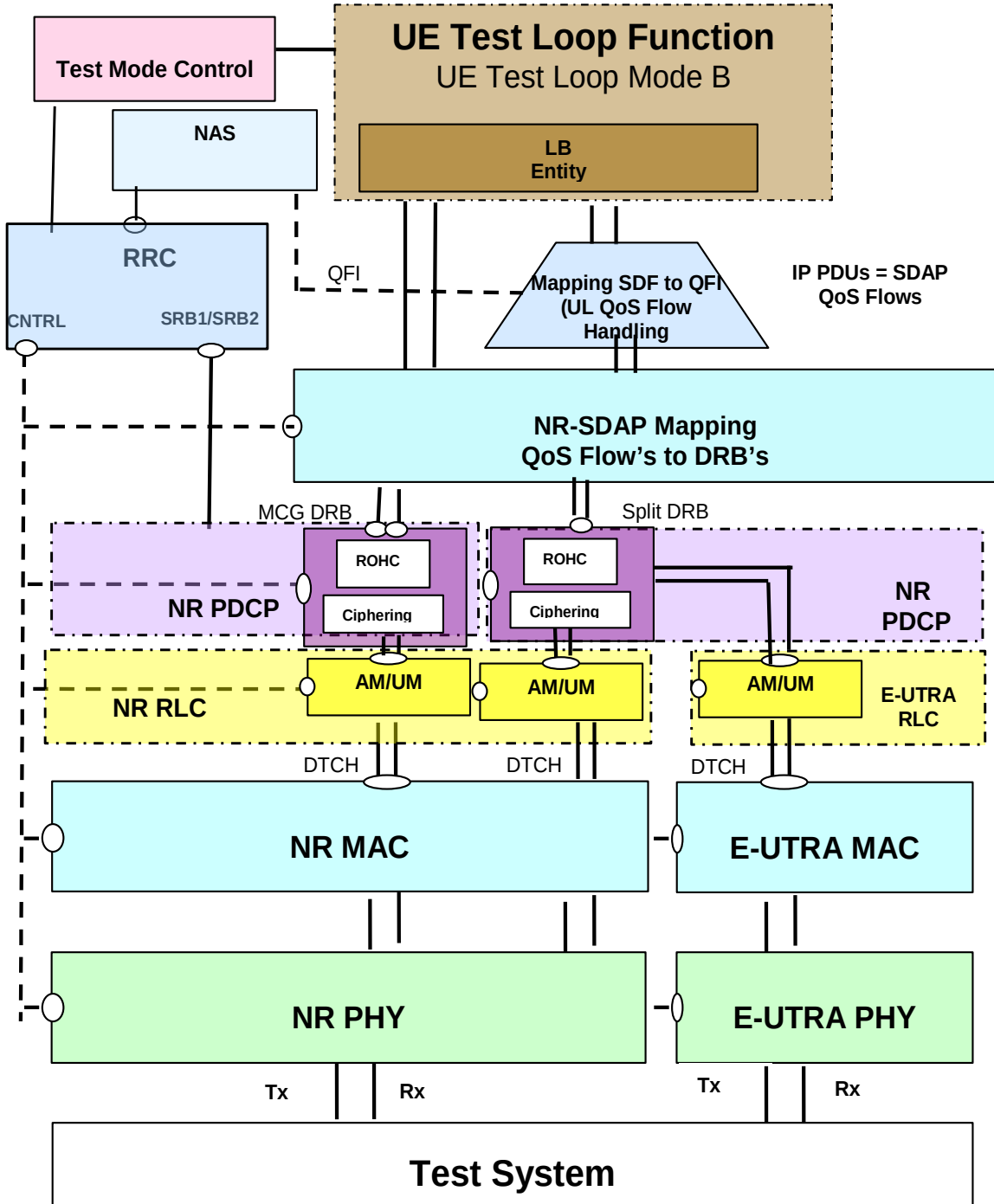

Figure 5.3.4.2.4-2: Model for Test Mode Control and UE Test Loop Mode B on UE side when NE-DC with MCG bearer and split bearers configured

5.3.4.2A UE test loop mode C operation

5.3.4.2A.1 General

UE test loop mode C is mandatory for NR UEs supporting MBS.

UE test loop mode C provides counting of successfully received MBS Packets on one MRB (Multicast MRB or Broadcast MRB) while UE is operating in NR/5GC.

- For Multicast MRB configuration:
 - Multicast MRB with DL only RLC-UM or bidirectional RLC-UM configuration for PTP transmission;
 - Multicast MRB with RLC-AM entity configuration for PTP transmission;
 - Multicast MRB with DL only RLC-UM entity for PTM transmission;
 - Multicast MRB with two RLC-UM entities, one DL only RLC-UM entity for PTP transmission and the other DL only RLC-UM entity for PTM transmission;
 - Multicast MRB with three RLC-UM entities, one DL RLC-UM entity and one UL RLC-UM entity for PTP transmission and the other DL only RLC-UM entity for PTM transmission;
 - Multicast MRB with two RLC entities, one RLC-AM entity for PTP transmission and the other DL only RLC-UM entity for PTM transmission.
- For Broadcast MRB configuration:
 - Broadcast MRB with one DL only RLC-UM entity for PTM transmission.

Figure 5.3.4.2A.1-1 shows a functional block diagram of UE test loop function for TC entity and UE test loop mode C for Multicast MRB. The MBMS Packet Counter function is configured to count successfully received MBS packets on one Multicast MRB configured by the SS when UE test loop mode C is activated.

Figure 5.3.4.2A.1-2 shows a functional block diagram of UE test loop function for TC entity and UE test loop mode C for Broadcast MRB. The MBMS Packet Counter function is configured to count successfully received MBS packets on one Broadcast MRB configured by the SS when UE test loop mode C is activated.

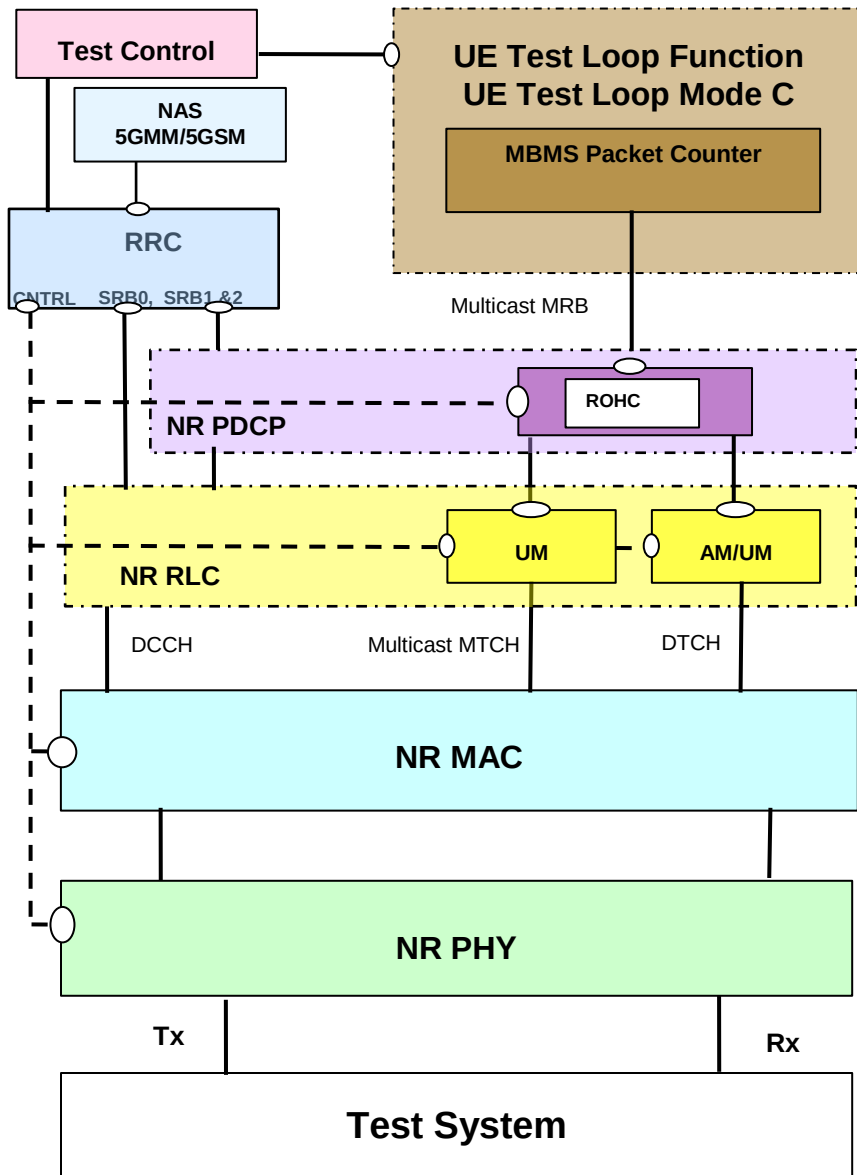

Figure 5.3.4.2A.1-1: Model for UE test loop mode C on UE side for Multicast MRB

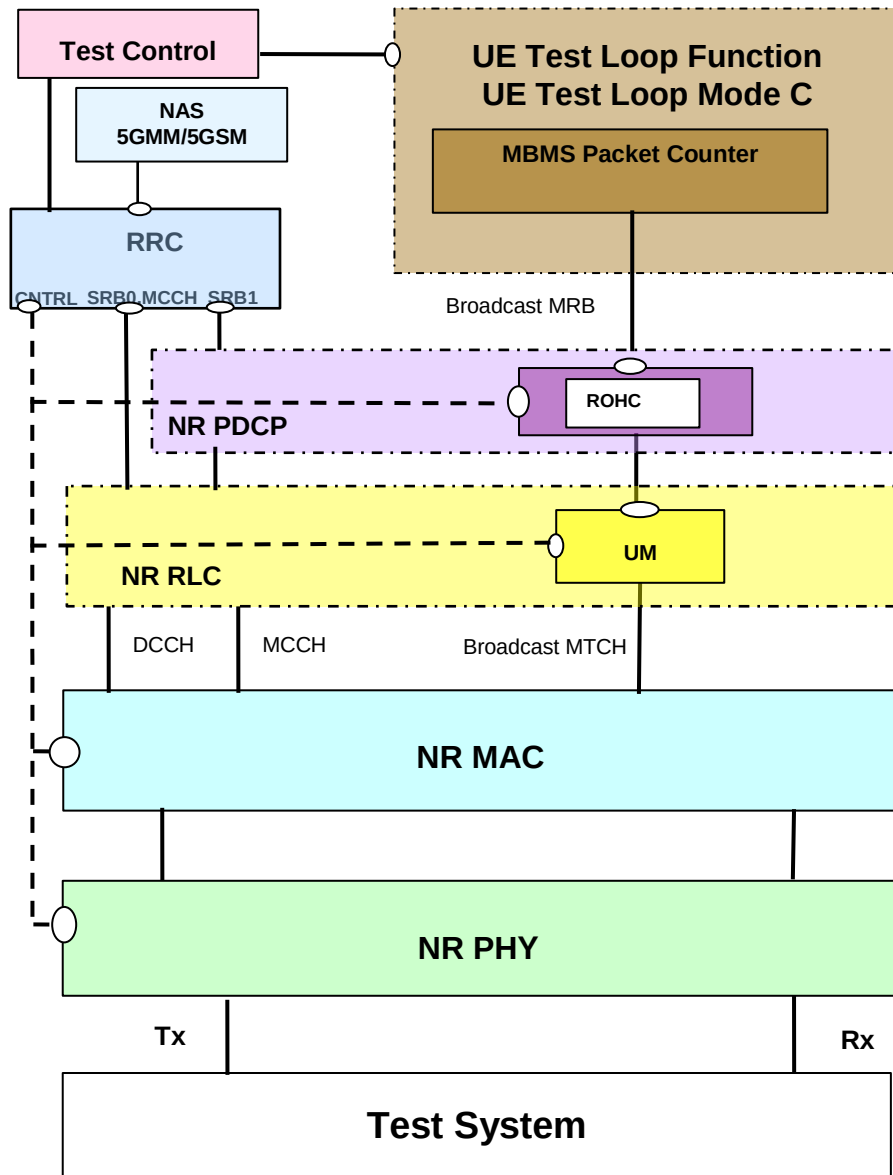

Figure 5.3.4.2A.1-2: Model for UE test loop mode C on UE side for Broadcast MRB

5.3.4.2A.2 Reception of MBS packets

For Broadcast MRB, upon receiving a MBS packet on the Broadcast MRB with Identity of the logical channel of broadcast MTCH configured in CLOSE UE TEST LOOP when operating in RRC_IDLE or RRC_CONNECTED or RRC_INACTIVE mode with UE test loop mode C active the UE shall:

- 1> if UE test loop mode C is active;
 - 2> increment MBMS_PACKET_COUNTER by 1;
- 1> else:
 - 2> the UE behaviour is unspecified.

For Multicast MRB, upon receiving a MBS packet on the Multicast MRB with MRB Identity configured in CLOSE UE TEST LOOP when operating in RRC_CONNECTED mode with UE test loop mode C active the UE shall:

- 1> if UE test loop mode C is active;
 - 2> increment MBMS_PACKET_COUNTER by 1;

1> else:

2> the UE behaviour is unspecified.

5.3.4.2A.3 Release of RRC connection

When the RRC connection is released then the UE shall:

1> if UE test loop mode C is active for Broadcast MRB:

2> keep UE test loop mode C active.

1> else

2> the UE behaviour is unspecified.

5.3.4.3 UE test loop mode E operation

5.3.4.3.0 General

UE test loop mode E is mandatory to all 5GS UEs supporting NR sidelink.

UE test loop mode E provides means for either transmit or receive of SDAP SDUs for PC5 QoS Flows while UE is operating in NR sidelink, as specified by the test loop mode E setup IE in the CLOSE UE TEST LOOP message.

For communication receive operation, UE test loop mode E provides counting of successfully received STCH PDCP SDUs, PSCCH PHY transport blocks and PSSCH PHY transport blocks while the UE is operating in NR sidelink communication mode.

For communication transmit operation, UE test loop mode E provides trigger for transmission of NR sidelink communication packets. For the V2X out-of-coverage scenarios this trigger utilises AT commands and requires an appropriate physical interface.

Figure 5.3.4.3.0-1 shows functional block diagrams of UE test loop function for the TMC entity and UE test loop mode E for the intra-frequency or inter-frequency concurrent operation case when Communication receive is indicated in UE test loop mode E setup IE.

Figure 5.3.4.3.0-2 shows functional block diagrams of UE test loop function for the TMC entity and UE test loop mode E for the PC5-only operation case when Communication receive is indicated in UE test loop mode E setup IE.

Figure 5.3.4.3.0-3 shows functional block diagrams of UE test loop function for the TMC entity and UE test loop mode E for the intra-frequency or inter-frequency concurrent operation case when Communication transmit is indicated in UE test loop mode E setup IE.

Figure 5.3.4.3.0-4 shows functional block diagrams of UE test loop function for the TMC entity and UE test loop mode E for the PC5-only operation case when Communication transmit is indicated in UE test loop mode E setup IE.

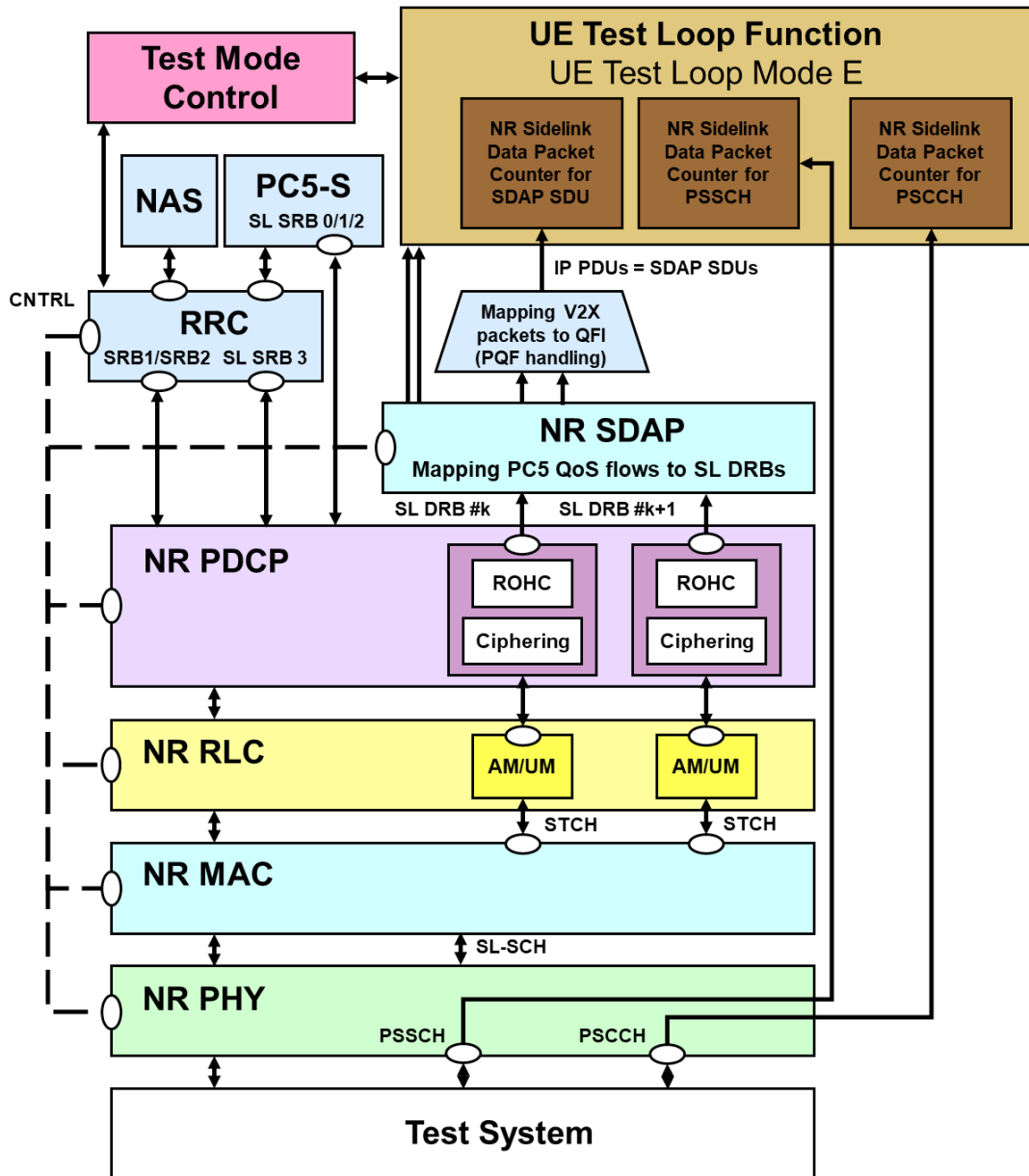

Figure 5.3.4.3.0-1: Model for Test Mode Control and UE Test Loop Mode E on UE side when UE is in intra-frequency or inter-frequency concurrent operation (Communication receive is indicated in UE test loop mode E setup IE)

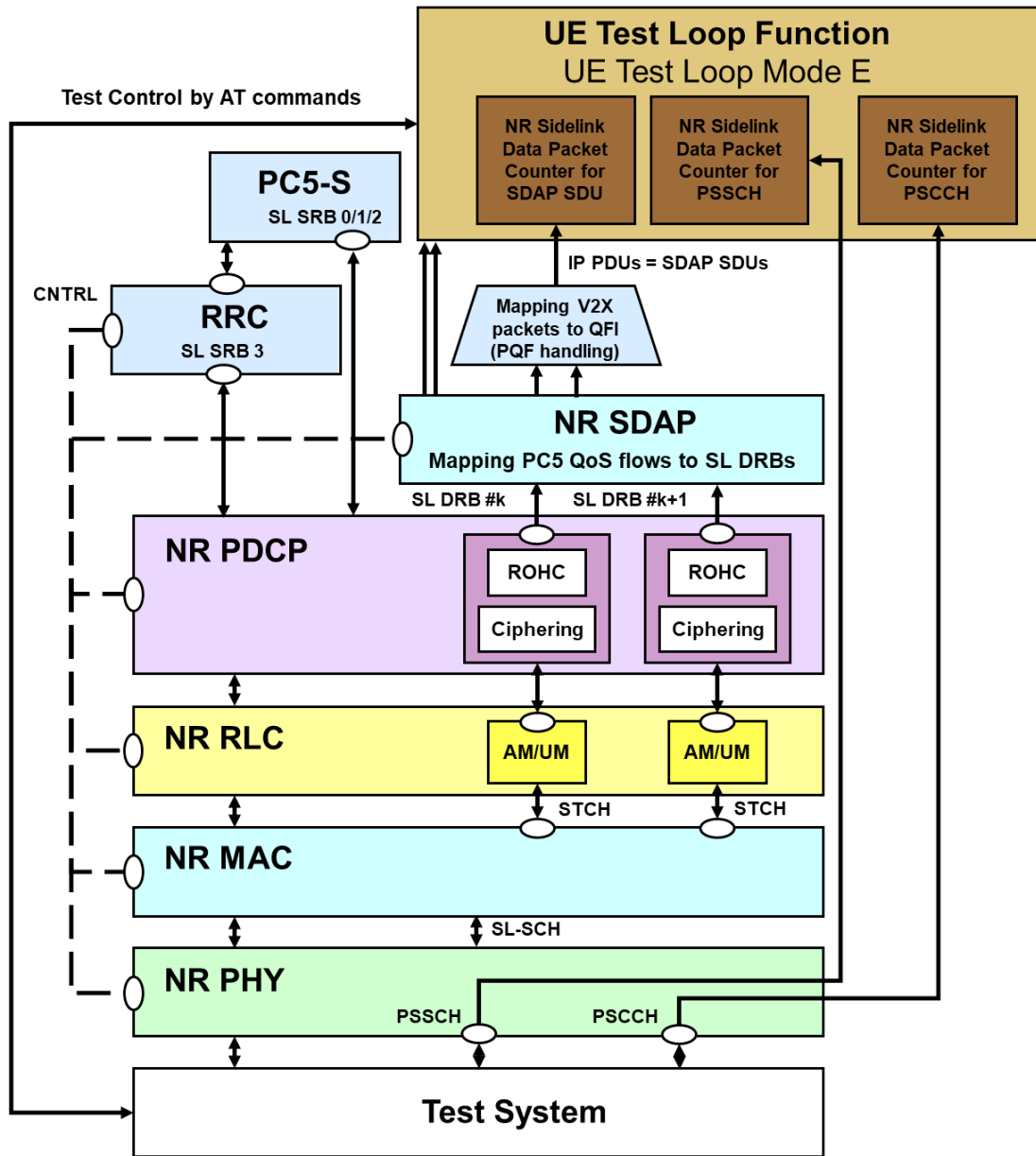

Figure 5.3.4.3.0-2: Model for Test Mode Control and UE Test Loop Mode E on UE side when UE is in PC5-only operation (Communication receive is indicated in UE test loop mode E setup IE)

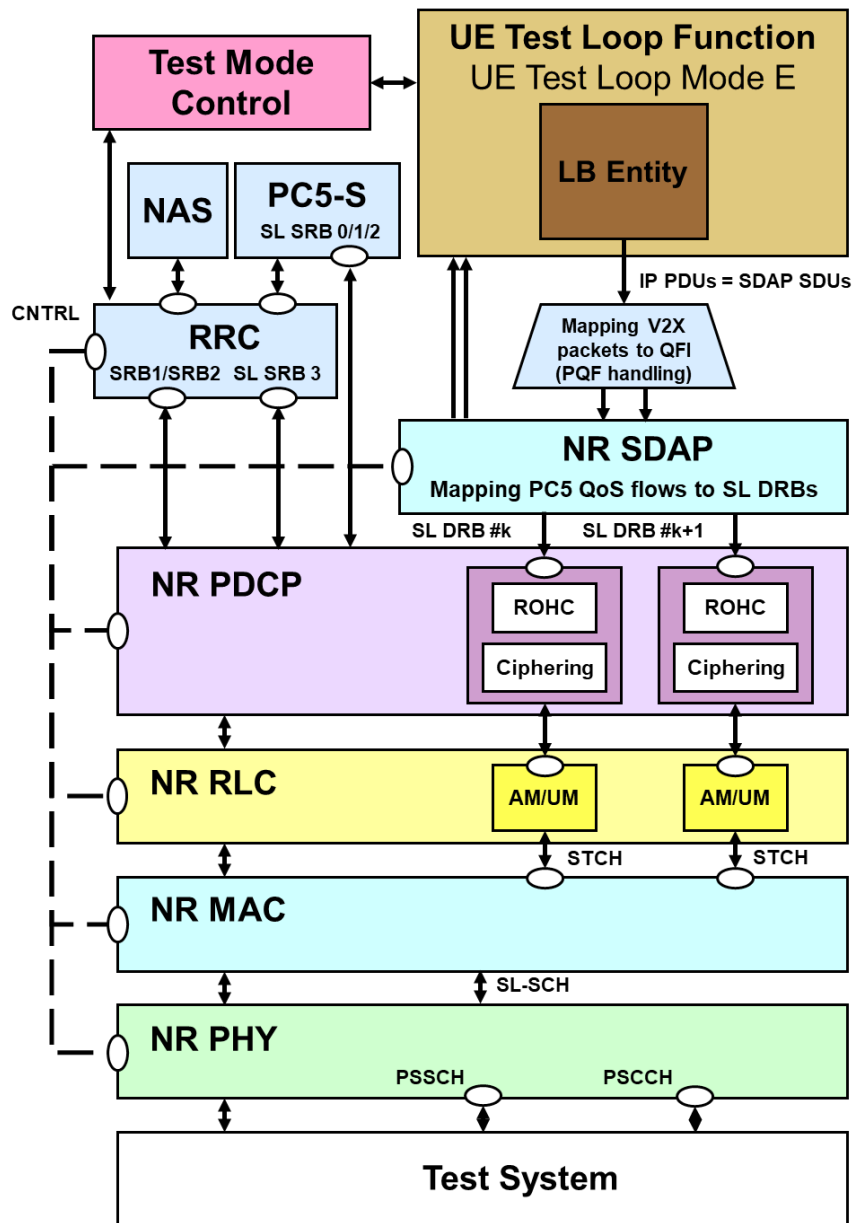

Figure 5.3.4.3.0-3: Model for Test Mode Control and UE Test Loop Mode E on UE side when UE is in intra-frequency or inter-frequency concurrent operation (Communication transmit is indicated in UE test loop mode E setup IE)

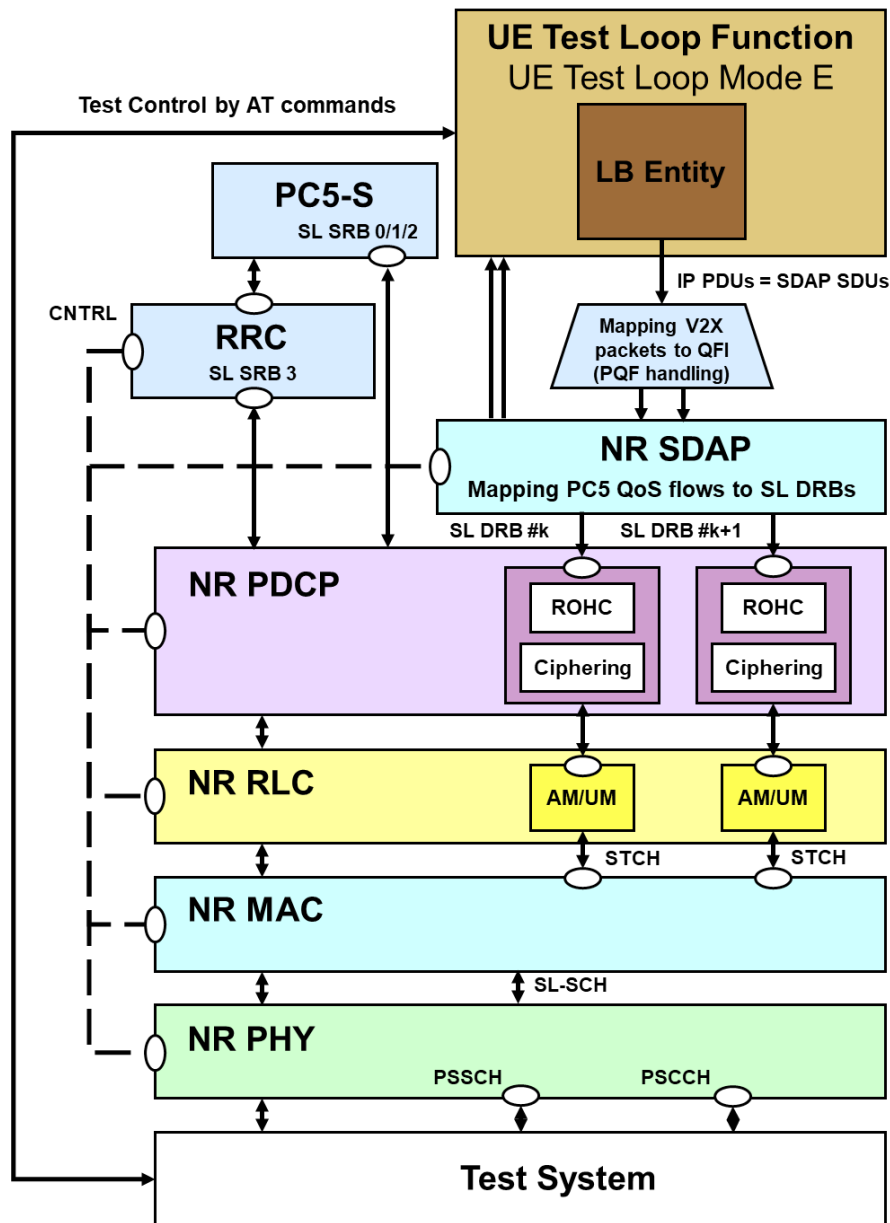

Figure 5.3.4.3.0-4: Model for Test Mode Control and UE Test Loop Mode E on UE side when UE is in PC5-only operation (when Communication transmit is indicated in UE test loop mode E setup IE)

The 5GS UE test loop mode E operation is the same as the one described in TS 36.509 [6], subclause 5.4.4c with the exceptions:

- where V2X is mentioned the same applies for NR sidelink.
- Subclause 5.4.4c.1 in TS 36.509 [6] is replaced by 5.3.4.3.1 in current specification.

5.3.4.3.1 Receive or Transmit NR sidelink Communication

When operating in NR idle or connected or any cell selection state or out-of-coverage state for NR sidelink test scenarios, with UE test loop mode E active, the UE shall be able to either receive or transmit NR sidelink communication packets based on the TEST_LOOP_MODE_E_TRIGGER being set as either RECEIVE or TRANSMIT, respectively. The UE shall:

- 1> if TEST_LOOP_MODE_E_ACTIVE is set to TRUE:
 - 2> if TEST_LOOP_MODE_E_TRIGGER is set to RECEIVE;
 - 3> upon successful reception of a SDAP SDU for NR sidelink communication data packet:

- 4> set MATCH to zero;
- 4> if PROSE_COMMUNICATION_MONITOR_N > 0
 - 5> for SL_ID = 0...(PROSE_COMMUNICATION_MONITOR_N-1):
 - 6> if Destination Layer-2 ID corresponding to the SDAP SDU equals PROSE_COMMUNICATION_DEST_ID(SL_ID):
 - 7> increment STCH_PACKET_COUNTER(SL_ID) by 1;
 - 7> set MATCH to one.
 - 4> if MATCH equal zero:
 - 5> increment STCH_PACKET_COUNTER(PROSE_COMMUNICATION_MONITOR_N) by 1.
- 3> upon successful reception of a PSCCH PHY transport block for NR sidelink communication control packet:
 - 4> increment PSCCH_PACKET_COUNTER(PROSE_COMMUNICATION_MONITOR_N) by 1.
- 3> upon successful reception of a PSSCH PHY transport block for NR sidelink communication data packet:
 - 4> set MATCH to zero;
 - 4> for SL_ID = 0...(PROSE_COMMUNICATION_MONITOR_N-1):
 - 5> if, in the received PSSCH PHY transport block, Destination Layer-2 ID for NR sidelink communication equals PROSE_COMMUNICATION_DEST_ID(SL_ID):
 - 6> increment PSSCH_PACKET_COUNTER(SL_ID) by 1;
 - 6> set MATCH to one.
 - 4> if MATCH equal zero:
 - 5> increment PSSCH_PACKET_COUNTER (PROSE_COMMUNICATION_MONITOR_N) by 1.
- 2> else if TEST_LOOP_MODE_E_TRIGGER is set to TRANSMIT;
 - 3> consider that a request from upper layers to transmit the packet for V2X service over PC5 has been received.
 - 4> use '00 00 00 01'H as the V2X service identifier provided by upper layer as specified in TS 24.587 [26] subclause 8.4.3.
 - 4> use '00 00 01 00'H as the application layer ID provided by upper layer as specified in TS 24.587 [26] subclause 8.4.4, if needed.
 - 4> create the SDAP SDU with payload size and contents as specified below, see Figure 5.3.4.3.1-1 and Table 5.3.4.3.1-1, consider the SDAP SDU as the packet corresponding to the V2X service identifier above, and provide it as the input of PQF handling depicted in Figure 5.3.4.3.0-3 or Figure 5.3.4.3.0-4 for transmission in every PSSCH duration according to subclause 5.2.2.1.1 of TS 38.321 [23] for NR sidelink communication.
- 2> else if TEST_LOOP_MODE_E_TRIGGER is set to TRANSMIT_SL_MIMO;
 - 3> consider that a request from upper layers to transmit the packet for V2X service over PC5 has been received.
 - 4> use '00 00 00 01'H as the V2X service identifier provided by upper layer as specified in TS 24.587 [26] subclause 8.4.3.

4> use '00 00 01 00'H as the application layer ID provided by upper layer as specified in TS 24.587 [26] subclause 8.4.4, if needed.

4> create the SDAP SDU with payload size and contents as specified below, see Figure 5.3.4.3.1-1 and Table 5.3.4.3.1-1, consider the SDAP SDU as the packet corresponding to the V2X service identifier above, and provide it as the input of PQF handling depicted in Figure 5.3.4.3.0-3 or Figure 5.3.4.3.0-4 for transmission in every PSSCH duration according to subclause 5.22.1.1 of TS 38.321 [23] for NR sidelink communication.

4> transmit PSSCH in SL-MIMO mode with 2-layer precoding matrix specified in TS 38.211 [25] subclause 8.3.1.4.

NOTE: The same SDAP SDU (1 packet) is transmitted (if permitted by test specific Layer 1 and Layer 2 configuration) by the UE in every PSSCH duration for NR sidelink communication during the entire duration test loop mode E is closed.

2> else:

3> the UE behaviour is unspecified.

1> else:

2> the UE behaviour is unspecified.

The SDAP SDU payload for NR sidelink communication packet when UE test loop mode E is active shall be as specified in Figure 5.3.4.3.1-1 and Table 5.3.4.3.1-1. The UE shall also transmit the corresponding SCI control information on PSCCH accordingly in the same slot on which the SDAP SDU is transmitted for NR sidelink Communication.

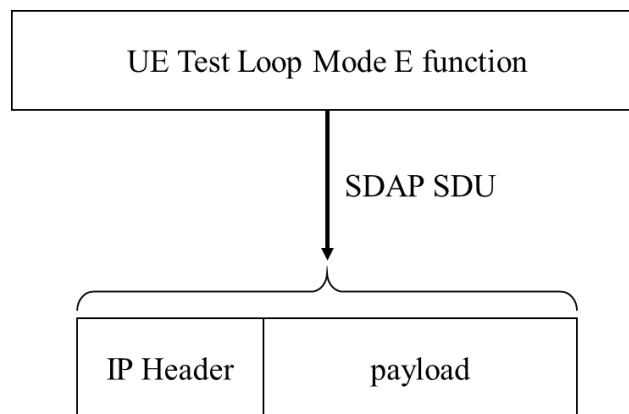

Figure 5.3.4.3.1-1: NR sidelink communication Transmit operation in UE test loop mode E

Table 5.3.4.3.1-1: SDAP SDU payload contents for NR sidelink communication transmit operation in UE test loop mode E

Parameter	Value
Size (N)	300 bytes
Payload	00...00

5.4 UE Beamlock test Function (UBF)

5.4.1 General

The UE Beamlock test function is intended for making the UE to lock the UE antenna pattern once it has formed a beam towards the base station (SS) direction following the cell identification procedure in preparation for subsequent test procedures. Activating the UBF shall lock the antenna pattern of all active intra-band component carriers and all MIMO layers affected by the test function.

The Beamlock test function is mandatory for applicable UEs operating in Frequency Range 2 (FR2).

The SS uses the UE Beamlock test mode activation procedure to command the UE to lock the UE antenna pattern. The Beamlock activation procedure can apply to UE transmitter and UE receiver beams either simultaneously or independently.

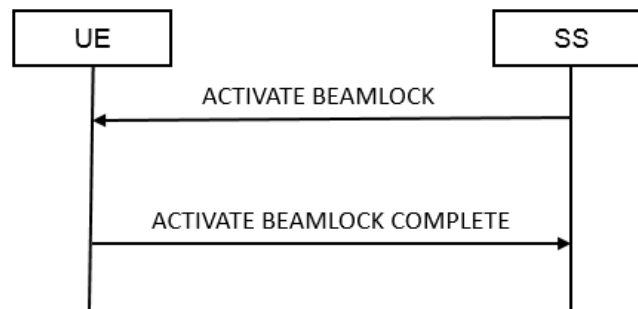

Figure 5.4.1-1: UE Beamlock test mode activation procedure

The SS uses the UE Beamlock test mode deactivation procedure to command the UE to re-tracking the beam towards the base station direction. The Beamlock deactivation procedure can apply to UE transmitter and UE receiver beams either simultaneously or independently.

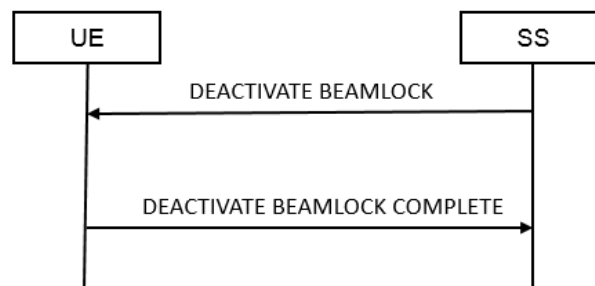

Figure 5.4.1-2: UE Beamlock test mode deactivation procedure

5.4.2 Activate Beamlock procedure

5.4.2.1 Initiation

The SS requests the UE to activate beamlock by transmitting an ACTIVATE BEAMLOCK message.

5.4.2.2 Reception of ACTIVATE BEAMLOCK message by UE

When UE receives ACTIVATE BEAMLOCK message then the UE shall:

- 1> if the UE is operating in FR2 AND is in RRC_CONNECTED state:
 - 2> if UE Beamlock test Function = 01
 - 3> Lock the UE antenna pattern with Tx only
 - 2> else if UE Beamlock test Function = 10
 - 3> Lock the UE antenna pattern with Rx only
 - 2> else if UE Beamlock test Function = 11
 - 3> Lock the UE antenna pattern with both TxRx
 - 2> Transmit ACTIVATE BEAMLOCK COMPLETE message
- 1> else:
 - 2> the UE behaviour is unspecified.

5.4.3 Deactivate Beamlock procedure

5.4.3.1 Initiation

The SS requests the UE to deactivate beamlock by transmitting a DEACTIVATE BEAMLOCK message. The SS should do this when the UE is in RRC_CONNECTED state.

5.4.3.2 Reception of DEACTIVATE BEAMLOCK message by UE

When UE receives DEACTIVATE BEAMLOCK message then the UE shall:

- 1> if the UE is operating in FR2 AND is in RRC_CONNECTED state AND the UE Beamlock test function is active:
 - 2> unlock the UE antenna pattern and transmit DEACTIVATE BEAMLOCK COMPLETE message;
- 1> else:
 - 2> the UE behaviour is unspecified.

5.4.3.3 Release of antenna beamlock by UE

When the UE leaves the RRC_CONNECTED state, the UE shall:

- 1> if the UE is operating in FR2 AND the UE Beamlock test Function is active
 - 2> unlock the UE antenna pattern;

5.5 UE SS-RSRPB per receiver branch reporting

5.5.1 General

In 38.215 [22], section 5.1.18 defines SS-RSRPB as below, with its applicability only to FR2 and in RRC_CONNECTED Mode.

Definition	<p>SS reference signal received power per branch (SS-RSRPB) is defined as the linear average over the power contributions (in [W]) of the resource elements that carry secondary synchronization signals (SS). The measurement time resource(s) for SS-RSRPB are confined within SS/PBCH Block Measurement Time Configuration (SMTTC) window duration.</p> <p>For SS-RSRPB determination demodulation reference signals for physical broadcast channel (PBCH) and, if indicated by higher layers, CSI reference signals in addition to secondary synchronization signals may be used. SS-RSRPB using demodulation reference signal for PBCH or CSI reference signal shall be measured by linear averaging over the power contributions of the resource elements that carry corresponding reference signals taking into account power scaling for the reference signals as defined in 3GPP TS 38.213 [5].</p> <p>SS-RSRPB shall be measured only among the reference signals corresponding to SS/PBCH blocks with the same SS/PBCH block index and the same physical-layer cell identity.</p> <p>If higher-layers indicate certain SS/PBCH blocks for performing SS-RSRPB measurements, then SS-RSRPB is measured only from the indicated set of SS/PBCH block(s).</p> <p>For frequency range 1, SS-RSRPB is not defined. For frequency range 2, SS-RSRPB shall be measured for each receiver branch based on the combined signal from antenna elements corresponding to the receiver branch.</p>
Applicable for	RRC_CONNECTED intra-frequency

The SS uses the SS-RSRPB reporting procedure to command the UE to report SS-RSRP per UE receiver branch. The report from the UE shall be a vector of values, where the number of the reported values equals the number of receiver branches on the UE.

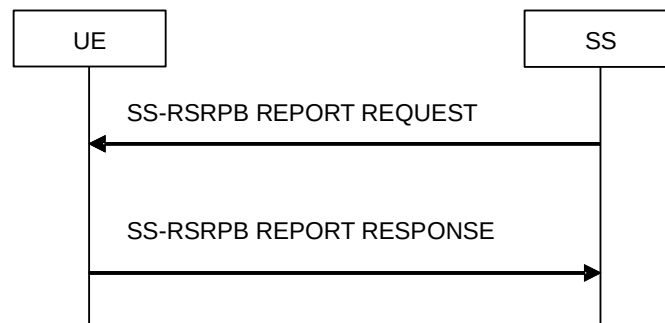

Figure 5.5.1-1: UE SS-RSRPB reporting procedure

5.5.2 Initiation

The SS requests the UE to start reporting SS-RSRP per receiver branch by transmitting a SS-RSRPB REPORT REQUEST message. And the UE responds back reporting SS-RSRP per receiver branch via SS-RSRPB REPORT RESPONSE.

5.5.3 Reception of SS-RSRPB REPORT REQUEST message by UE

When the UE receives SS-RSRPB REPORT REQUEST message then the UE shall:

- 1> if the UE is operating in FR2 AND in RRC_CONNECTED state:
 - 2> if quantityConfigRS-Index is configured to UE by RRC Signalling
 - 3> use the L3 filter coefficient given by quantityConfigRS-Index.
 - 2> else
 - 3> use default L3 filter coefficient of fc4.

2> if the MeasObjectId signalled by the IE SS-RSRPB Measurement Config and ReportConfigNR with reportType set to periodical which is associated to this MeasObjectNR are configured to the UE by RRC Signalling

3> Reply with the SS-RSRPB REPORT RESPONSE using the Measurement configuration as in the Measurement Object identified in the SS-RSRPB Measurement Config and reportInterval, reportAmount as in the associated ReportConfigNR

3> Report the SS-RSRPB measurement for the best SSB-ID of the serving PCI configured in the MeasObject

3> FFS to have multiple cells and/or SSB-ID

2> else if the MeasObjectId signalled by the IE SS-RSRPB Measurement Config is configured to the UE by RRC signalling but no ReportConfigNR with reportType set to periodical is associated to this MeasObjectNR:

3> Reply with the SS-RSRPB REPORT RESPONSE using the Measurement configuration as in the Measurement Object identified in the SS-RSRPB Measurement Config and default reportInterval of 640ms, and default reportAmount of r16

3> Report the SS-RSRPB measurement for the serving PCI and best SSB-ID configured in the MeasObject

3> FFS to have multiple cells and/or SSB-ID

2> else the UE behaviour is unspecified.

1> else:

2> the UE behaviour is unspecified.

The SS-RSRPB Report Request & SS-RSRPB Report Response Message Octets are defined below in Section 6.5.

5.6 UE Positioning test mode procedures

5.6.1 Reset UE Positioning Stored Information

5.6.1.1 General

Same as TS 36.509 [6], subclause 5.5.1.1.

5.6.1.2 Initiation

Same as TS 36.509 [6], subclause 5.5.1.2.

5.6.1.3 Reception of RESET UE POSITIONING STORED INFORMATION message by UE

When UE receives RESET UE POSITIONING STORED INFORMATION message then the UE shall:

1> if the IE "UE Positioning Technology" has the value 'AGNSS':

2> discard any stored GNSS reference time, reference position, and any other aiding data obtained or derived during the previous test instance (e.g. expected ranges and Doppler);

2> temporarily disable any sensor data (if applicable) that can aid the positioning for the duration of the subsequent positioning procedure.

1> if the IE "UE Positioning Technology" has the value 'OTDOA':

2> discard any stored OTDOA reference and neighbour cell info assistance data;

2> use the reference cell in the provided OTDOA assistance data as reference cell for reporting RSTD measurements in the subsequent positioning procedure.

NOTE 1: Where OTDOA is mentioned this applies to OTDOA using LTE cells.

1> if the IE "UE Positioning Technology" has the value 'MBS':

2> discard any stored MBS assistance data and information obtained or derived during the previous test instance (e.g. Beacon PN code and slot information and code phase measurements);

2> temporarily disable any sensor data (if applicable) that can aid the positioning for the duration of the subsequent positioning procedure.

1> if the IE "UE Positioning Technology" has the value 'WLAN':

2> discard any stored WLAN assistance data and information obtained or derived during the previous test instance;

1> if the IE "UE Positioning Technology" has the value 'Bluetooth':

2> discard any stored Bluetooth data obtained or derived during the previous test instance;

1> if the IE "UE Positioning Technology" has the value 'Sensor':

2> discard any stored Sensor assistance data and information obtained or derived during the previous test instance;

1> if the IE "UE Positioning Technology" has the value 'DL-TDOA':

2> discard any stored DL-PRS assistance data and information obtained or derived during the previous test instance;

1> if the IE "UE Positioning Technology" has the value 'DL-AoD':

2> discard any stored DL-PRS assistance data and information obtained or derived during the previous test instance;

1> if the IE "UE Positioning Technology" has the value 'Multi-RTT':

2> discard any stored UL-SRS configuration and DL-PRS assistance data obtained or derived during the previous test instance;

1> otherwise:

2> ignore the message.

5.6.2 Update UE Location Information

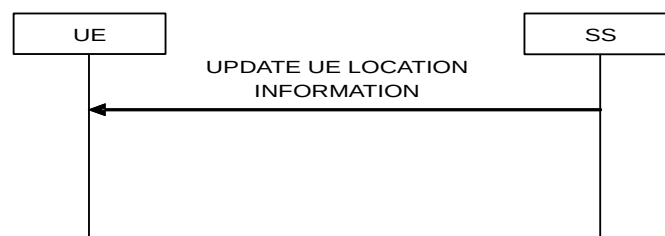

Figure 5.6.2-1: Update UE Location Information procedure

5.6.2.1 General

Same as TS 36.509 [6], subclause 5.5.2.1.

5.6.2.2 Initiation

Same as TS 36.509 [6], subclause 5.5.2.2.

5.6.2.3 Reception of UPDATE UE LOCATION INFORMATION message by UE

Same as TS 36.509 [6], subclause 5.5.2.3.

5.6.3 UTC time reset

FFS

5.7 NSSAI delete test function

5.7.1 General

The SS use the NSSAI delete test procedure to delete different type of NSSAI information in the UE, see Figure 5.7.1-1. The different types of NSSAI information that can be deleted in a NSSAI DELETE REQUEST message are Default configured NSSAI, Configured NSSAI or Allowed NSSAI information, see clause 6.7. The NSSAI delete test procedure is limited to delete one type of NSSAI information. To delete more than one type of NSSAI information the SS needs to repeat the procedure for each type of NSSAI information.

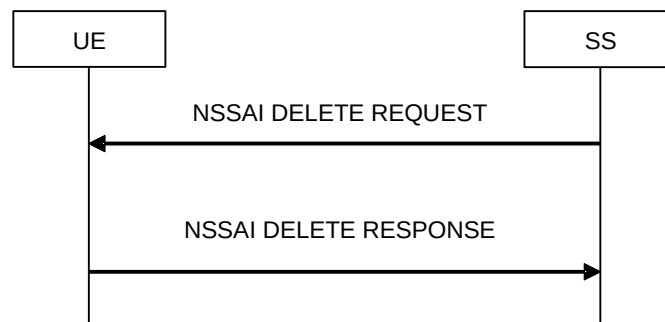

Figure 5.7.1-1: NSSAI delete test procedure

5.7.2 Initiation

The SS requests the UE to delete NSSAI information by transmitting a NSSAI DELETE REQUEST message and the UE confirms the deletion of the requested NSSAI information by responding with a NSSAI DELETE RESPONSE message.

5.7.3 Reception of NSSAI DELETE REQUEST message by UE

When UE receives NSSAI DELETE REQUEST message then the UE shall:

- 1> if the UE is operating in RRC_CONNECTED state:
 - 2> if Delete NSSAI type = 00:
 - 3> Delete the default configured NSSAI stored at the UE if any.
 - 2> else if Delete NSSAI type = 01:
 - 3> if Octets 3,4 and 5 all set to "00000000":
 - 4> Delete configured NSSAI for all PLMNs stored at the UE if any.

- 3> else if at least one of octets 3,4 or 5 <> "00000000":
 - 4> Delete configured NSSAI for the PLMN indicated by octet 3,4 and 5 stored at the UE if any.
- 2> else if Delete NSSAI type = 10:
 - 3> if Octets 3,4 and 5 all set to "00000000":
 - 4> if Access type =00:
 - 5> Delete allowed NSSAI associated with 3GPP access for all PLMNs stored at the UE if any.
 - 4> else if Access type =01:
 - 5> Delete allowed NSSAI associated with non-3GPP access for all PLMNs stored at the UE if any.
 - 4> else if Access type =10:
 - 5> Delete allowed NSSAI associated with both 3GPP and non-3GPP access for all PLMNs stored at the UE if any.
 - 4> else
 - 5> The UE behaviour is unspecified.
 - 3> else if At least one of octets 3,4 or 5 <> "00000000":
 - 4> if Access type =00:
 - 5> Delete allowed NSSAI associated with 3GPP access for the PLMN indicated by octet 3,4 and 5 stored at the UE if any.
 - 4> else if Access type =01:
 - 5> Delete allowed NSSAI associated with non-3GPP access for the PLMN indicated by octet 3,4 and 5 stored at the UE if any.
 - 4> else if Access type =10:
 - 5> Delete allowed NSSAI associated with both 3GPP and non-3GPP access for the PLMN indicated by octet 3,4 and 5 stored at the UE if any.
 - 4> else
 - 5> The UE behaviour is unspecified.
 - 2> else
 - 3> The UE behaviour is unspecified.
 - 2> Transmit NSSAI DELETE RESPONSE message.

1> else:

 - 2> the UE behaviour is unspecified.

5.8 Set UAI test function

5.8.1 General

The SS uses the Set UAI test procedure to trigger a change of preference in the UE that will cause the indication of UE Assistance Information (UAI) by the UE, see figure 5.8.1-1. The different types of information that can be sent in a SET UAI REQUEST is preferred RRC state, see clause 6.8.

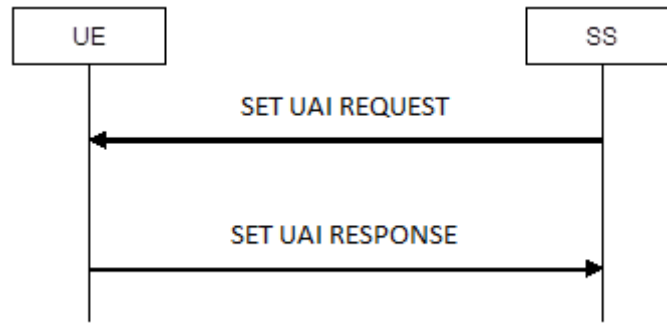

Figure 5.8.1-1: Set UAI test procedure

5.8.2 Initiation

The SS requests the UE to set the preferred RRC state of UE Assistance Information by transmitting a SET UAI REQUEST message and the UE confirms by responding with a SET UAI RESPONSE message.

5.8.3 Reception of SET UAI REQUEST message by UE

When UE receives SET UAI REQUEST message then the UE shall:

- 1> if the UE is operating in RRC_CONNECTED state:
 - 2> set its preferred RRC state within the release preference, to the equivalent value as received in the Preferred RRC State of the SET UAI REQUEST message.
 - 2> transmit SET UAI RESPONSE message.
- 1> else:
 - 2> the UE behaviour is unspecified.

5.9 NR Sidelink Packet Counter reporting procedure

5.9.1 Request NR Sidelink Packet Counter value

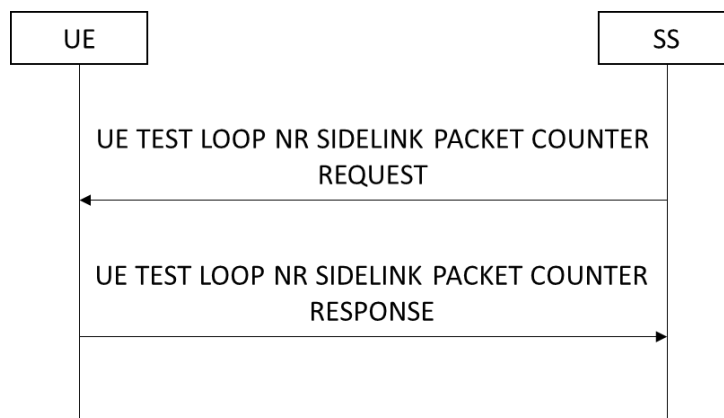

Figure 5.9.1-1: NR Sidelink Packet Counter reporting procedure based on TC protocol messages

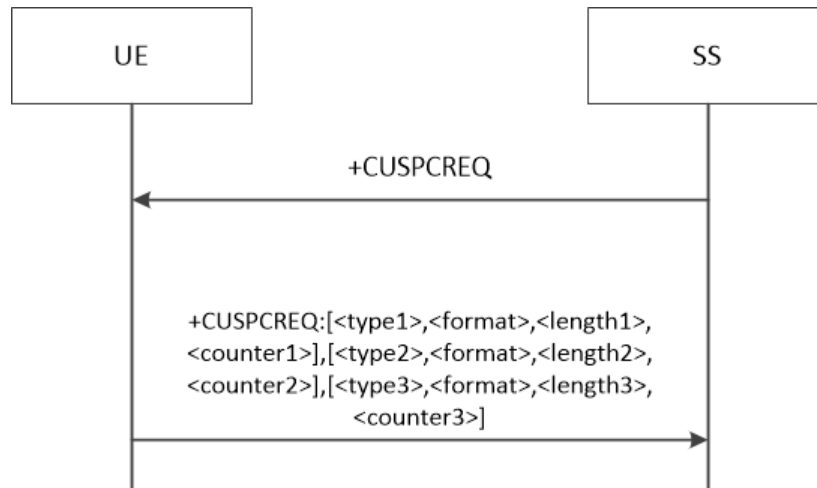

Figure 5.9.1-2: NR Sidelink Packet Counter reporting procedure based on AT Commands

5.9.1.1 General

The SS uses the NR Sidelink Packet Counter reporting procedure to request reporting of current NR sidelink related state variables. For mode E the state variables STCH_PACKET_COUNTER, PSCCH_PACKET_COUNTER and PSSCH_PACKET_COUNTER of NR sidelink are reported.

5.9.1.2 Initiation

The SS requests the UE to report its current value of STCH_PACKET_COUNTER, PSCCH_PACKET_COUNTER and PSSCH_PACKET_COUNTER of NR sidelink for test loop mode E by transmitting an UE TEST LOOP NR SIDELINK PACKET COUNTER REQUEST message or by transmitting an AT Command +CUSPCREQ.

5.9.1.3 Reception of UE TEST LOOP NR SIDELINK COUNTER REQUEST by the UE

Upon receiving the UE TEST LOOP NR SIDELINK PACKET COUNTER REQUEST message the UE shall:

1> if TEST_LOOP_MODE_E_ACTIVE is TRUE:

2> set the IE NR Sidelink PSCCH Packet Counter(s) Value in the UE TEST LOOP PROSE COUNTER RESPONSE message to the value of the state variable(s) PSCCH_PACKET_COUNTER(SL_ID) with SL_ID = 0...PROSE_COMMUNICATION_MONITOR_N;

2> set the IE NR Sidelink STCH Packet Counter(s) Value in the UE TEST LOOP PROSE COUNTER RESPONSE message to the value of the state variable STCH_PACKET_COUNTER(SL_ID) with SL_ID = 0...PROSE_COMMUNICATION_MONITOR_N;

2> set the IE NR Sidelink PSSCH Packet Counter(s) Value in the UE TEST LOOP PROSE COUNTER RESPONSE message to the value of the state variable(s) PSSCH_PACKET_COUNTER(SL_ID) with SL_ID = 0...PROSE_COMMUNICATION_MONITOR_N;

2> send the UE TEST LOOP NR SIDELINK COUNTER RESPONSE message.

1> else:

2> the UE behaviour is unspecified.

5.9.1.4 Reception of AT Command +CUSPCREQ by the UE

Upon receiving the AT Command +CUSPCREQ the UE shall:

1> if TEST_LOOP_MODE_E_ACTIVE is TRUE:

2> in the response message of command +CUSPCREQ, set the parameter <type1> to 2; set the parameter <format> to 1; set the parameter <length1> to 4*(PROSE_COMMUNICATION_MONITOR_N+1); set the parameter <counter1> to the value of the state variable(s) PSCCH_PACKET_COUNTER(SL_ID) with SL_ID = 0...PROSE_COMMUNICATION_MONITOR_N;

2> in the response message of command +CUSPCREQ, set the parameter <type2> to 2; set the parameter <format> to 1; set the parameter <length2> to 4*(PROSE_COMMUNICATION_MONITOR_N+1); set the parameter <counter2> to the value of the state variable STCH_PACKET_COUNTER(SL_ID) with SL_ID = 0...PROSE_COMMUNICATION_MONITOR_N;

2> in the response message of command +CUSPCREQ, set the parameter <type3> to 2; set the parameter <format> to 1; set the parameter <length3> to 4*PROSE_COMMUNICATION_MONITOR_N+1; set the parameter <counter3> to the value of the state variable(s) PSSCH_PACKET_COUNTER(SL_ID) with SL_ID = 0...PROSE_COMMUNICATION_MONITOR_N;

2> send the response message +CUSPCREQ: [<type1>,<format>,<length1>,<counter1>], [<type2>,<format>,<length2>,<counter2>], [<type3>,<format>,<length3>,<counter3>].

1> else:

2> the UE behaviour is unspecified.

5.10 Set UL Message test function

5.10.1 General

Same as TS 36.509 [6], subclause 5.10.1.

5.10.2 Initiation

Same as TS 36.509 [6], subclause 5.10.2.

5.10.3 Reception of SET UL MESSAGE REQUEST message by UE

Same as TS 36.509 [6], subclause 5.10.3 with the following exception:

- the predefined UE capability container is defined in Annex A.1

5.11 UE Power Limit Function (UPLF)

5.11.1 General

The UE Power Limit Function is intended for the SS to communicate to the UE to apply a backoff of transmitted power on the NR primary component carrier when in FR2 carrier aggregation mode. On activation of this test function, the UE shall apply a configured power backoff on the primary component carrier to provide sufficient power head room for the other (secondary) component carrier(s). The UE power limit function is mandatory for applicable UEs operating in Frequency Range 2 (FR2) and supporting UL CA from Rel-16.

The SS uses the UE Power Limit test mode activation procedure to send a power limit request to the UE. The transmission from the SS shall be a vector of values, where the number of the reported values equals the back-off or power limit to be applied by the UE.

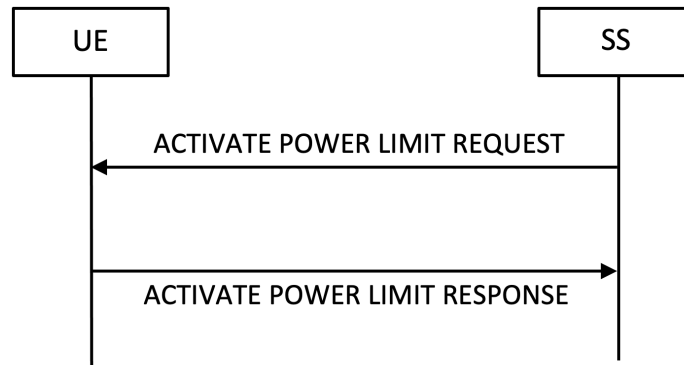

Figure 5.11.1-1: Activate Power Limit test mode procedure

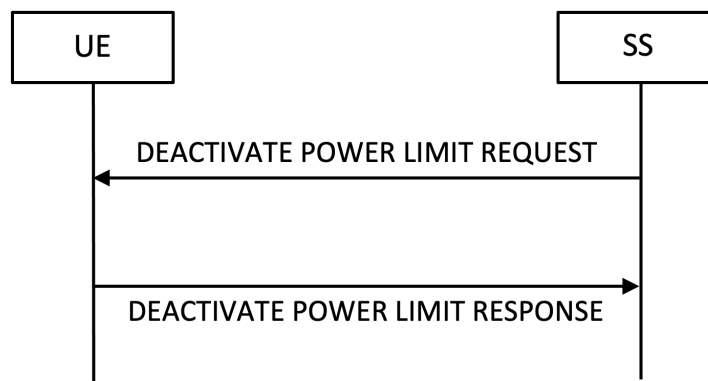

Figure 5.11.1-2: Deactivate Power Limit test mode procedure

5.11.2 Activate Power Limit Procedure

5.11.2.1 Initiation

The SS requests the UE to apply the power limit by transmitting an ACTIVATE POWER LIMIT REQUEST message. The UE confirms that the power limit function is activated by sending an ACTIVATE POWER LIMIT RESPONSE.

5.11.2.2 Reception of ACTIVATE POWER LIMIT REQUEST by UE

When the UE receives the ACTIVATE POWER LIMIT REQUEST message, then the UE shall:

- 1> if the UE is operating in FR2 AND is in RRC_CONNECTED state:
 - 2> UE limits power on PCell according to a back-off defined by $X_{\max,PCell}$.
- 1> else;
 - 2> the UE behaviour is unspecified

The ACTIVATE POWER LIMIT REQUEST and ACTIVATE POWER LIMIT RESPONSE Message Octets and power back-off $X_{\max,PCell}$ are defined below in Section 6.11.

5.11.3 Deactivate Power Limit Procedure

5.11.3.1 Initiation

The SS requests the UE to deactivate from the power limit state by transmitting a DEACTIVATE POWER LIMIT REQUEST message. The SS should do this when the UE is in RRC_CONNECTED state.

5.11.3.2 Reception of DEACTIVATE POWER LIMIT REQUEST message by UE

When UE receives DEACTIVATE POWER LIMIT REQUEST message then the UE shall:

- 1> if the UE is operating in FR2 AND is in RRC_CONNECTED state AND the UE Power Limit test function is active:
 - 2> Remove UE power limit on PCell and transmit DEACTIVATE POWER LIMIT RESPONSE message.
- 1> else:
 - 2> the UE behaviour is unspecified.

5.11.3.3 Removal of power limits by UE

When the UE leaves the RRC_CONNECTED state, the UE shall:

- 1> if the UE is operating in FR2 AND the UE Power limit test Function is active
 - 2> remove UE power limit on PCell;

5.12 MBMS Packet Counter reporting procedure

5.12.1 Request MBMS Packet Counter value

Same as TS 36.509 [6], subclause 5.6 with the following exception:

- MBMS Packet is replaced by MBS Packet

5.13 Set MUSIM UAI test function

5.13.1 General

The SS uses the Set MUSIM UAI test procedure to trigger a change of preference in the MUSIM UE that will cause the indication of UE Assistance Information (UAI) by the UE, see figure 5.8.1-1. The different types of information that can be sent in a SET MUSIM UAI REQUEST is preferred RRC state and gap preference for MUSIM, see clause 6.13.

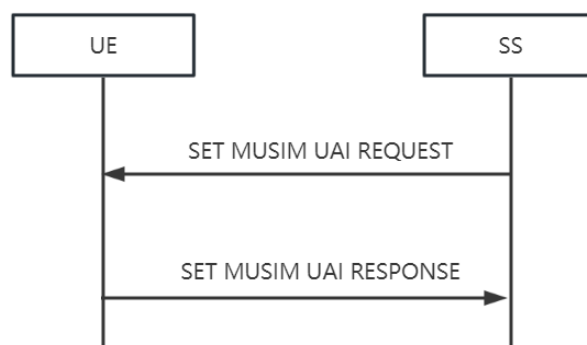

Figure 5.13.1-1: Set MUSIM UAI test procedure

5.13.2 Initiation

The SS requests the UE to set the MUSIM related UE Assistance Information by transmitting a SET MUSIM UAI REQUEST message and the UE confirms by responding with a SET MUSIM UAI RESPONSE message.

5.13.3 Reception of SET MUSIM UAI REQUEST message by UE

When UE receives SET MUSIM UAI REQUEST message then the UE shall:

1> if the MUSIM UE is operating in RRC_CONNECTED state:

2> set its preferred RRC state within the release preference, to the equivalent value as received in the *musim-PreferredRRC-State-r17* of the SET MUSIM UAI REQUEST message.

2> transmit SET MUSIM UAI RESPONSE message.

1> if the UE has a preference for MUSIM periodic gap(s):

2> set its preferred gap preference, to the equivalent value as received in the *musim-GapPreferenceList* of the SET MUSIM UAI REQUEST message.

2> transmit SET MUSIM UAI RESPONSE message.

else:

2> the UE behaviour is unspecified.

6 Test Mode Control message definitions

6.1 General

Clause 6 describes only TMC protocol messages.

When UE under test is operated in EN-DC or NGEN-DC the TMC messages are sent using the E-UTRA RRC *DLInformationTransfer* and *ULInformationTransfer* procedures, see TS 36.331 [10], subclauses 5.6.1 and 5.6.2.

When UE under test is operated in NR or NE-DC the TMC messages are sent using the NR RRC *DLInformationTransfer* and *ULInformationTransfer* procedures, see TS 38.331 [11], subclauses 5.7.1 and 5.7.2.

NOTE 1: A message received with skip indicator different from 0 will be ignored.

NOTE 2: For general definition of Layer 3 message format see TS 24.007 [7], clause 11.

NOTE 3: 5GS use the same protocol discriminator value ("1111") as E-UTRA, UTRA and GSM/GPRS as specified in TS 24.007 [7], subclause 11.2.3.1.1. 5GS test control messages the message type value series 101xxxxx is reserved, where x represents 0 or 1. The message type values 0000xxxx to 1001xxxx are reserved to E-UTRA, UTRA and GSM/GPRS as specified in TS 36.509 [6], TS 34.109 [8] and TS 44.014 [9]. For 5GS test control messages that are common with E-UTRA control messages in TS 36.509 [6] the 5GS test control messages use the same message type values as used for the E-UTRA test control messages in TS 36.509 [6].

All the TMC messages are integrity protected and ciphered according to TS 24.301 [17] subclause 4.4 or TS 24.501 [21] subclause 4.4 depending on whether the TMC message is sent via EPS or 5GC.

6.2 Test mode messages

6.2.1 ACTIVATE TEST MODE

Same as TS 36.509 [6], subclause 6.5.

6.2.2 ACTIVATE TEST MODE COMPLETE

Same as TS 36.509 [6], subclause 6.6.

6.2.3 DEACTIVATE TEST MODE

Same as TS 36.509 [6], subclause 6.7.

6.2.4 DEACTIVATE TEST MODE COMPLETE

Same as TS 36.509 [6], subclause 6.8.

6.3 Test loop messages

6.3.1 CLOSE UE TEST LOOP

Same as TS 36.509 [6], subclause 6.1 with the following exception:

- The supported test modes for 5GS are limited to those specified in subclause 5.3.4.
- LB Setup DRB#k IE is:

8	7	6	5	4	3	2	1	bit no.
Z15	Z14	Z13	Z12	Z11	Z10	Z9	Z8	octet 1
Z7	Z6	Z5	Z4	Z3	Z2	Z1	Z0	octet 2
Reserved		Q5	Q4	Q3	Q2	Q1	Q0	octet 3

Z15..Z0 = Uplink PDCP SDU size in bits 0.. 12160 (binary coded, Z15 is most significant bit and Z0 least significant bit). See Note 1.

Q5 = 0 for E-UTRA Data Radio Bearers and Q5 = 1 for NR Data Radio Bearers

Q4..Q0 = 0..31 representing DRB-Identity -1, where DRB-Identity identifies the data radio bearer in accordance to TS 36.331 [10] for E-UTRA Data Radio Bearers and TS 38.331 [11] for NR Data Radio Bearers [11] (binary coded, Q4 is most significant bit and Q0 least significant bit).

NOTE 1: The UL PDCP SDU size is limited to 12160 bits (1520 octets).

NOTE 2: A "LB Setup DRB IE" is only needed for a DRB if UL PDCP SDU scaling is needed. If there is no "LB Setup DRB IE" associated with a DRB in the CLOSE UE TEST LOOP message, then the same size of the PDCP SDU received in downlink is returned in uplink.

NOTE 3: The UL PDCP SDU size shall be byte aligned (i.e. multiple of 8 bits) according to TS 36.323 [18] clause 6.2.1 for E-UTRA Data Radio Bearers and TS 38.323 [19] clause 6.2.1 for NR Data Radio Bearers.

- The Communication Transmit or Receive message in UE test loop mode E setup is as below:

And where UE test loop mode C setup is:

	8	7	6	5	4	3	2	1	
	MRB ID								
									octet 1
									octet 2
									octet 3

Where MRB ID is:

8	7	6	5	4	3	2	1	bit no.	
Reserved							C0	octet 1	
A8	A7	A6	A5	A4	A3	A2	A1	octet 2	
A0	Reserved								octet 3

A8..A0 = 0..511 representing MRB-Identity -1, where MRB-Identity identifies the Multicast MRB in accordance to TS 38.331 [11] (binary coded, A8 is most significant bit and A0 least significant bit).

A4..A0= 0..31 representing Identity of the logical channel of broadcast MTCH -1, where Identity of the logical channel of broadcast MTCH identifies the Broadcast MRB in accordance to TS 38.321 [23] (binary coded, A4 is most significant bit and A0 least significant bit).

C0=0 is used to trigger the UE to count the MBS packet on Multicast MRB of the MRB-Identity configured in A8..A0; C0=1 is used to trigger the UE to count the MBS packet on Broadcast MRB of the Identity of the logical channel of broadcast MTCH configured in A4..A0.

And where UE test loop mode E setup is:

	8	7	6	5	4	3	2	1	
	Length of UE test loop mode E Monitor setup contents in bytes								Octet 1
	Communication Transmit or Receive								Octet 2
	Monitor list								Octet 3
									Octet N+2 or Octet 3*N+2

where Communication Transmit or Receive is:

8	7	6	5	4	3	2	1	bit no.
Reserved						E1	E0	octet 1

E0 = 0 is used to trigger the UE to continuously monitor and receive NR sidelink communication message (on STCH, PSCCH and PSSCH), and E0 = 1 is used to trigger the UE to start continuous transmitting NR sidelink communication messages (on STCH).

If E0 = 1, E1 = 1 is used to indicate UE shall transmit with 2-layer SL-MIMO transmission with precoding matrix defined in TS 38.211 [25] subclause 8.3.1.4, and E1 = 0 is used to indicate UE shall transmit with single antenna port; otherwise E1 is used as reserved bit.

6.3.2 CLOSE UE TEST LOOP COMPLETE

Same as TS 36.509 [6], subclause 6.2.

6.3.3 OPEN UE TEST LOOP

Same as TS 36.509 [6], subclause 6.3.

6.3.4 OPEN UE TEST LOOP COMPLETE

Same as TS 36.509 [6], subclause 6.4.

6.3.5 Void

6.3.6 Void

6.4 Beamlock messages

6.4.1 ACTIVATE BEAMLOCK

This message is only sent in the direction SS to UE.

Information Element	Reference	Presence	Format	Length
Protocol discriminator	TS 24.007 [5], sub clause 11.2.3.1.1	M	V	$\frac{1}{2}$
Skip indicator	TS 24.007 [5], sub clause 11.2.3.1.2	M	V	$\frac{1}{2}$
Message type		M	V	1
UE Beamlock test Function		M	V	1

where message type is:

8	7	6	5	4	3	2	1	bit no.
1	0	1	0	0	0	0	0	octet 1

where UE Beamlock test Function is:

8	7	6	5	4	3	2	1	bit no.
						X1	X2	octet 1

where X1,X2 = 01 for activate beamlock of Tx only, 10 for activate beamlock of Rx only and 11 for activate beamlock of both TxRx.

NOTE: X1,X2 = 00 is not used

6.4.2 ACTIVATE BEAMLOCK COMPLETE

This message is only sent in the direction UE to SS.

Information Element	Reference	Presence	Format	Length
Protocol discriminator	TS 24.007 [5], sub clause 11.2.3.1.1	M	V	$\frac{1}{2}$
Skip indicator	TS 24.007 [5], sub clause 11.2.3.1.2	M	V	$\frac{1}{2}$
Message type		M	V	1

where message type is:

8	7	6	5	4	3	2	1	bit no.
1	0	1	0	0	0	0	1	octet 1

6.4.3 DEACTIVATE BEAMLOCK

This message is only sent in the direction SS to UE.

Information Element	Reference	Presence	Format	Length
Protocol discriminator	TS 24.007 [5], sub clause 11.2.3.1.1	M	V	½
Skip indicator	TS 24.007 [5], sub clause 11.2.3.1.2	M	V	½
Message type		M	V	1

where message type is:

8	7	6	5	4	3	2	1	bit no.
1	0	1	0	0	0	1	0	octet 1

6.4.4 DEACTIVATE BEAMLOCK COMPLETE

This message is only sent in the direction UE to SS.

Information Element	Reference	Presence	Format	Length
Protocol discriminator	TS 24.007 [5], sub clause 11.2.3.1.1	M	V	½
Skip indicator	TS 24.007 [5], sub clause 11.2.3.1.2	M	V	½
Message type		M	V	1

where message type is:

8	7	6	5	4	3	2	1	bit no.
1	0	1	0	0	0	1	1	octet 1

6.5 UE SS-RSRP per receiver branch reporting messages

6.5.1 SS-RSRPB REPORT REQUEST

This message is only sent in the direction SS to UE.

Information Element	Reference	Presence	Format	Length
Protocol discriminator	TS 24.007 [5], subclause 11.2.3.1.1	M	V	½
Skip indicator	TS 24.007 [5], sub clause 11.2.3.1.2	M	V	½
Message type		M	V	1
SS-RSRPB Measurement Config		M	V	1

where message type is:

8	7	6	5	4	3	2	1	bit no.
1	0	1	0	0	1	0	0	octet 1

where SS-RSRPB Measurement Config is:

8	7	6	5	4	3	2	1	bit no.
X8	X7	X6	X5	X4	X3	X2	X1	octet 1

This maps to the MeasObjectId as configured by the RRC Reconfig Message.

6.5.2 SS-RSRPB REPORT RESPONSE

This message is only sent in the direction UE to SS representing the measured SS-RSRPB. The reporting range of SS-RSRPB (0 to 126) maps to the RSRP values in dBm as per Table 10.1.6.1-1 in TS 38.133. To report SS-RSRPB (0 to 126) per measured SSB, UE shall send 3 Octets, the First Octet reporting the Measured SSB ID (values 0 to 63 representing 6 bits X1 to X6 of Octet 1), Second Octet reporting SS-RSRPB for Branch#0 and third Octet reporting SS-RSRPB for Branch#1.

Information Element	Reference	Presence	Format	Length
Protocol discriminator	TS 24.007 [5], subclause 11.2.3.1.1	M	V	½
Skip indicator	TS 24.007 [5], sub clause 11.2.3.1.2	M	V	½
Message type		M	V	1
SS-RSRPB report response param		M	V	3

where message type is:

8	7	6	5	4	3	2	1	bit no.
1	0	1	0	0	1	0	1	octet 1

where SS-RSRPB report response param is:

8	7	6	5	4	3	2	1	bit no.
Reserved		X6	X5	X4	X3	X2	X1	octet 1
16	15	14	13	12	11	10	9	bit no.
X16	X15	X14	X13	X12	X11	X10	X9	octet 2
24	23	22	21	20	19	18	17	bit no.
X24	X23	X22	X21	X20	X19	X18	X17	octet 3

where X1 to X24 spanning over three octets shall have the following definition:

Definition	8	7	6	5	4	3	2	1	bit no.
SSB ID	Reserved		X6	X5	X4	X3	X2	X1	octet 1
RSRPB Branch #0	0	X15	X14	X13	X12	X11	X10	X9	octet 2
RSRPB Branch #1	0	X23	X22	X21	X20	X19	X18	X17	octet 3

6.6 UE Positioning messages

6.6.1 RESET UE POSITIONING STORED INFORMATION

This message is only sent in the direction SS to UE.

Information Element	Reference	Presence	Format	Length
Protocol discriminator	TS 24.007 [7], subclause 11.2.3.1.1	M	V	½
Skip indicator	TS 24.007 [7], sub clause 11.2.3.1.2	M	V	½
Message type		M	V	1
UE Positioning Technology		M	V	1

where message type is:

8	7	6	5	4	3	2	1	bit no.
1	0	0	0	1	0	0	0	octet 1

where UE Positioning Technology is a single octet IE:

8	7	6	5	4	3	2	1	bit no.
UE Positioning Technology								octet 1

UE Positioning Technology value

Bits

8 7 6 5 4 3 2 1

0 0 0 0 0 0 0 0	AGNSS
0 0 0 0 0 0 0 1	OTDOA
0 0 0 0 0 0 1 0	MBS
0 0 0 0 0 0 1 1	WLAN
0 0 0 0 0 1 0 0	Bluetooth
0 0 0 0 0 1 0 1	Sensor
0 0 0 0 0 1 1 0	Multi-RTT
0 0 0 0 0 1 1 1	DL-TDOA
0 0 0 0 1 0 0 0	DL-AoD

All other cause values are reserved for future use.

6.6.2 UPDATE UE LOCATION INFORMATION

Same as TS 36.509 [6], subclause 6.12.

6.7 NSSAI delete messages

6.7.1 NSSAI DELETE REQUEST

This message is only sent in the direction SS to UE.

Information Element	Reference	Presence	Format	Length
Protocol discriminator	TS 24.007 [5], sub clause 11.2.3.1.1	M	V	½
Skip indicator	TS 24.007 [5], sub clause 11.2.3.1.2	M	V	½
Message type		M	V	1
Delete NSSAI type		M	V	1
Configured NSSAI		CV- ConfNSSAI	V	3
Allowed NSSAI		CV- AllowedNSSAI	V	4

Condition	Explanation
CV- ConfNSSAI	This IE is mandatory present if the IE "Delete NSSAI type" is set to Delete Configured NSSAI. Else it shall be absent.
CV- AllowedNSSAI	This IE is mandatory present if the IE "Delete NSSAI type" is set to Delete Allowed NSSAI. Else it shall be absent.

where message type is:

8	7	6	5	4	3	2	1	bit no.
1	0	1	0	0	1	1	0	octet 1

where Delete NSSAI type is:

8	7	6	5	4	3	2	1	bit no.
Reserved						E1	E0	octet 2

E1=0 and E0=0; Delete default configured NSSAI.

E1=0 and E0=1; Delete Configured NSSAI.

E1=1 and E0=0: Delete Allowed NSSAI.

where Configured NSSAI type

E1=1 and E0=1: Reserved.

8	7	6	5	4	3	2	1	bit no.
MCC digit 2				MCC digit 1				octet 3
MNC digit 3				MCC digit 3				octet 4
MNC digit 2				MNC digit 1				octet 5

Octets 3,4 and 5 all set to "00000000": Delete configured NSSAI for all configured PLMNs.

At least one of octets 3,4 or 5 <> "00000000": Delete configured NSSAI for the PLMN indicated by octet 3,4 and 5,

- where octets 3 and 4 (bits 1 to 4) is MCC, Mobile country code. The MCC is BCD coding. The MCC field is coded as in ITU-T Rec. E212 [39], annex A; and
- where octet 4 (bits 5 to 8) and octet 5 is MNC, Mobile network code. The MNC is BCD coding. The MNC shall consist of 2 or 3 digits. If only two digits are used in the MNC then shall MNC digit 3 be set to "1111".

where Allowed NSSAI:

8	7	6	5	4	3	2	1	bit no.
MCC digit 2				MCC digit 1				octet 3
MNC digit 3				MCC digit 3				octet 4
MNC digit 2				MNC digit 1				octet 5
Reserved						A1	A0	octet 6

Octets 3,4 and 5 all set to "00000000": Delete NSSAI for all allowed PLMNs.

At least one of octets 3,4 or 5 <> "00000000": Delete allowed NSSAI for the PLMN indicated by octet 3,4 and 5,

- where octets 3 and 4 (bits 1 to 4): MCC, Mobile country code. The MCC is BCD Coding. The MCC field is coded as in ITU-T Rec. E212 [39], annex A; and
- where octet 4 (bits 5 to 8) and octet 5 is MNC, Mobile network code. The MNC is BCD coding. The MNC shall consist of 2 or 3 digits. If only two digits are used in the MNC then shall MNC digit 3 be coded as "1111"; and
- where octet 6 is

8	7	6	5	4	3	2	1	bit no.
Reserved						A1	A0	octet 6

where A0 and A1 define the access type:

A1	A0	Value
0	0	3GPP access
0	1	Non-3GPP access
1	0	3GPP access and non-3GPP access
1	1	reserved

6.7.2 NSSAI DELETE RESPONSE

This message is only sent in the direction UE to SS.

Information Element	Reference	Presence	Format	Length
Protocol discriminator	TS 24.007 [5], sub clause 11.2.3.1.1	M	V	½
Skip indicator	TS 24.007 [5], sub clause 11.2.3.1.2	M	V	½
Message type		M	V	1

where message type is:

8	7	6	5	4	3	2	1	bit no.
1	0	1	0	0	1	1	1	octet 1

6.8 SET UAI REQUEST

6.8.1 SET UAI REQUEST

This message is only sent in the direction SS to UE.

Information Element	Reference	Presence	Format	Length
Protocol discriminator	TS 24.007 [5], sub clause 11.2.3.1.1	M	V	½
Skip indicator	TS 24.007 [5], sub clause 11.2.3.1.2	M	V	½
Message type		M	V	1
Preferred RRC State		M	V	1

where message type is:

8	7	6	5	4	3	2	1	bit no.
1	0	1	0	1	0	0	0	octet 1

where Preferred RRC State is:

8	7	6	5	4	3	2	1	bit no.
Reserved						E1	E0	octet 2

E1=0 and E0=0; idle.

E1=0 and E0=1; inactive.

E1=1 and E0=0; connected.

E1=1 and E0=1; outOfConnected.

6.8.2 SET UAI RESPONSE

This message is only sent in the direction UE to SS.

Information Element	Reference	Presence	Format	Length
Protocol discriminator	TS 24.007 [5], sub clause 11.2.3.1.1	M	V	½
Skip indicator	TS 24.007 [5], sub clause 11.2.3.1.2	M	V	½
Message type		M	V	1

where message type is:

8	7	6	5	4	3	2	1	bit no.
1	0	1	0	1	0	0	1	octet 1

6.9 NR SIDELINK PACKET COUNTER reporting messages

6.9.1 UE TEST LOOP NR SIDELINK PACKET COUNTER REQUEST

This message is only sent in the direction SS to UE.

Information Element	Reference	Presence	Format	Length
Protocol discriminator	TS 24.007 [5], subclause 11.2.3.1.1	M	V	1/2
Skip indicator	TS 24.007 [5], subclause 11.2.3.1.2	M	V	1/2
Message type		M	V	1

where message type is:

8	7	6	5	4	3	2	1	bit no.
1	0	1	0	1	0	1	0	octet 1

6.9.2 UE TEST LOOP NR SIDELINK PACKET COUNTER RESPONSE

This message is only sent in the direction UE to SS.

Information Element	Reference	Presence	Format	Length
Protocol discriminator	TS 24.007 [5], subclause 11.2.3.1.1	M	V	1/2
Skip indicator	TS 24.007 [5], subclause 11.2.3.1.2	M	V	1/2
Message type		M	V	1
NR Sidelink PSCCH Packet Counter(s) Value		CV-ModeE	TLV	4*(N ^c +1)+2
NR Sidelink STCH Packet Counter(s) Value		CV-ModeE	TLV	4*(N ^c +1)+2
NR Sidelink PSSCH Packet Counter(s) Value		CV-ModeE	TLV	4*(N ^c +1)+2

Condition	Explanation
CV-ModeE	This IE is mandatory present if TEST_LOOP_MODE_E_ACTIVE is TRUE else it shall be absent. N ^c = PROSE_COMMUNICATION_MONITOR_N.

where message type is:

8	7	6	5	4	3	2	1	bit no.
1	0	1	0	1	0	1	1	octet 1

And where NR Sidelink PSCCH Packet Counter(s) Value is:

8 7 6 5 4 3 2 1	
NR Sidelink PSCCH Packet Counter(s) Value type	octet 1
Length of NR Sidelink PSCCH Packet Counter(s) Value contents in bytes	octet 2
NR Sidelink PSCCH Packet Counter IE #0	octet 3 octet 4 octet 5 octet 6
...	
NR Sidelink PSCCH Packet Counter IE #N ^C	octet 3+4 * N ^C octet 4+4 * N ^C octet 5+4 * N ^C octet 6+4 * N ^C

And where NR Sidelink PSCCH Packet Counter(s) Value type is:

8	7	6	5	4	3	2	1	bit no.
0	0	0	0	0	0	0	1	octet 1

And where NR Sidelink PSCCH Packet Counter IE #n is:

D31	D30	D29	D28	D27	D26	D25	D24	octet 1
D23	D22	D21	D20	D19	D18	D17	D16	octet 2
D15	D14	D13	D12	D11	D10	D9	D8	octet 3
D7	D6	D5	D4	D3	D2	D1	D0	octet 4

D31..D0 = PSCCH packet counter 0.. 4294967295 (binary coded, D31 is most significant bit and D0 least significant bit) corresponding to PSCCH_PACKET_COUNTER(SL_ID = n).

And where NR Sidelink STCH Packet Counter(s) Value is:

8 7 6 5 4 3 2 1	
NR Sidelink STCH Packet Counter(s) Value type	octet 1
Length of NR Sidelink STCH Packet Counter(s) Value in bytes	octet 2
NR Sidelink STCH Packet Counter IE #0	octet 3 octet 4 octet 5 octet 6
...	
NR Sidelink STCH Packet Counter IE #N ^C	octet 3+4 * N ^C octet 4+4 * N ^C octet 5+4 * N ^C octet 6+4 * N ^C

where NR Sidelink STCH Packet Counter(s) Value type is:

8	7	6	5	4	3	2	1	bit no.
0	0	0	0	0	0	1	0	octet 1

And where NR Sidelink STCH Packet Counter IE #n is:

E31	E30	E29	E28	E27	E26	E25	E24	octet 1
E23	E22	E21	E20	E19	E18	E17	E16	octet 2
E15	E14	E13	E12	E11	E10	E9	E8	octet 3
E7	E6	E5	E4	E3	E2	E1	E0	octet 4

E31..E0 = STCH Packet Counter value 0.. 4294967295 (binary coded, E31 is most significant bit and E0 least significant bit) corresponding to STCH_PACKET_COUNTER(SL_ID = n).

And where NR Sidelink PSSCH Packet Counter(s) Value is:

8 7 6 5 4 3 2 1	
NR Sidelink PSSCH Packet Counter(s) Value type	octet 1
Length of NR Sidelink PSSCH Packet Counter(s) Value contents in bytes	octet 2
NR Sidelink PSSCH Packet Counter IE #0	octet 3 octet 4 octet 5 octet 6
...	
NR Sidelink PSSCH Packet Counter IE #N ^c	octet 3+4 * N ^c octet 4+4 * N ^c octet 5+4 * N ^c octet 6+4 * N ^c

And where NR Sidelink PSSCH Packet Counter(s) Value type is:

8	7	6	5	4	3	2	1	bit no.
0	0	0	0	0	0	1	1	octet 1

And where NR Sidelink PSSCH Packet Counter IE #n is:

F31	F30	F29	F28	F27	F26	F25	F24	octet 1
F23	F22	F21	F20	F19	F18	F17	F16	octet 2
F15	F14	F13	F12	F11	F10	F9	F8	octet 3
F7	F6	F5	F4	F3	F2	F1	F0	octet 4

F31..F0 = PSSCH packet counter 0.. 4294967295 (binary coded, F31 is most significant bit and F0 least significant bit) corresponding to PSSCH_PACKET_COUNTER(SL_ID = n).

6.10 SET UL MESSAGE

6.10.1 SET UL MESSAGE REQUEST

Same as TS 36.509 [6], subclause 6.19.1

6.10.2 SET UL MESSAGE RESPONSE

Same as TS 36.509 [6], subclause 6.19.2.

6.11 Power Limit messages

6.11.1 ACTIVATE POWER LIMIT REQUEST

The values sent the SS as part of this test function maps to the values defined in Table 6.11.1-1.

For intra-band contiguous FR2 UL-CA scenarios where it is critical to prevent drop of the secondary component carrier(s) due to prioritization rules in section 7.5 of TS 38.213, a parameter $X_{\max,f,PCell}$ is defined for the Pcell such that

$$X_{\max,PCell} = 10 \log_{10}(\text{total aggregated BW/PCell BW})$$

$X_{\max,i,PCell}$ is the back-off in transmit power applied on the primary component carrier from $P_{\text{CMAX},f,c}$. This ensure sufficient power allocation is possible on the secondary component carrier(s)

This message is only sent in the direction SS to UE.

Information Element	Reference	Presence	Format	Length
Protocol discriminator	TS 24.007 [7], subclause 11.2.3.1.1	M	V	½
Skip indicator	TS 24.007 [7], subclause 11.2.3.1.2	M	V	½
Message type		M	V	1
TOTAL NR AGGREGATED BANDWIDTH		M	V	1
PCELL NR BANDWIDTH		M	V	1

where message type is:

8	7	6	5	4	3	2	1	bit no.
1	0	1	0	1	1	1	0	octet 1

where TOTAL NR AGGREGATED BANDWIDTH is a single octet IE:

8	7	6	5	4	3	2	1	bit no.
X8	X7	X6	X5	X4	X3	X2	X1	octet 1

and represents the total NR aggregated bandwidth as per the equation below:

$$total\ aggregated\ BW\ [MHz] = 50 \times \sum_{i=1}^{i=8} X_i \times 2^{(i-1)}$$

where PCELL NR BANDWIDTH is a single octet IE:

8	7	6	5	4	3	2	1	bit no.
X8	X7	X6	X5	X4	X3	X2	X1	octet 1

and represents the PCell NR bandwidth as per the equation below:

$$PCell\ BW\ [MHz] = 50 \times \sum_{i=1}^{i=8} X_i \times 2^{(i-1)}$$

6.11.2 ACTIVATE POWER LIMIT RESPONSE

This message is only sent in the direction UE to SS.

Information Element	Reference	Presence	Format	Length
Protocol discriminator	TS 24.007 [5], sub clause 11.2.3.1.1	M	V	½
Skip indicator	TS 24.007 [5], sub clause 11.2.3.1.2	M	V	½
Message Type		M	V	1

where message type is:

8	7	6	5	4	3	2	1	bit no.
1	0	1	0	1	1	1	1	octet 1

6.11.3 DEACTIVATE POWER LIMIT REQUEST

This message is only sent in the direction SS to UE

Information Element	Reference	Presence	Format	Length
Protocol discriminator	TS 24.007 [5], sub clause 11.2.3.1.1	M	V	½
Skip indicator	TS 24.007 [5], sub clause 11.2.3.1.2	M	V	½
Message Type		M	V	1

where message type is:

8	7	6	5	4	3	2	1	bit no.
1	0	1	1	0	0	0	0	octet 1

6.11.4 DEACTIVATE POWER LIMIT RESPONSE

This message is only sent in the direction UE to SS.

Information Element	Reference	Presence	Format	Length
Protocol discriminator	TS 24.007 [5], sub clause 11.2.3.1.1	M	V	½
Skip indicator	TS 24.007 [5], sub clause 11.2.3.1.2	M	V	½
Message Type		M	V	1

where message type is:

8	7	6	5	4	3	2	1	bit no.
1	0	1	1	0	0	0	1	octet 1

6.12 UE TEST LOOP MODE C MBMS PACKET COUNTER reporting messages

6.12.1 UE TEST LOOP MODE C MBMS PACKET COUNTER REQUEST

Same as TS 36.509 [6], subclause 6.10

6.12.2 UE TEST LOOP MODE C MBMS PACKET COUNTER RESPONSE

Same as TS 36.509 [6], subclause 6.11.

6.13 SET MUSIM UAI REQUEST

6.13.1 SET MUSIM UAI REQUEST

This message is only sent in the direction SS to UE.

Information Element	Reference	Presence	Format	Length
Protocol discriminator	TS 24.007 [5], sub clause 11.2.3.1.1	M	V	$\frac{1}{2}$
Skip indicator	TS 24.007 [5], sub clause 11.2.3.1.2	M	V	$\frac{1}{2}$
Message type		M	V	1
<i>musim-PreferredRRC-State</i>		M	V	1
<i>musim-GapPreferenceList</i>		<i>CV-musimGap</i>	TLV	$5*(N^c+1)+2$

Condition	Explanation
<i>CV-musimGap</i>	$0 \leq N^c \leq 3$.

where message type is:

8	7	6	5	4	3	2	1	bit no.
1	0	1	1	0	0	1	0	octet 1

where *musim-PreferredRRC-State* is:

8	7	6	5	4	3	2	1	bit no.
Reserved						E1	E0	octet 3

E1=0 and E0=0; idle.

E1=0 and E0=1; inactive.

E1=1 and E0=0; outOfConnected.

E1=1 and E0=1; Reserved.

where *musim-GapPreferenceList* is:

8	7	6	5	4	3	2	1	
<i>musim-GapPreferenceList</i> Value type								octet 1
Length of <i>musim-GapPreferenceList</i> Value contents in bytes								octet 2
<i>musim-GapPreferenceList</i> IE #0								octet 3 octet 4 octet 5 octet 6 octet 7
...								
<i>musim-GapPreferenceList</i> IE #N ^c								octet 3+5 * N ^c octet 4+5 * N ^c octet 5+5 * N ^c octet 6+5 * N ^c octet 7+5 * N ^c

And where *musim-GapPreferenceList* Value type is:

8	7	6	5	4	3	2	1	bit no.
0	0	0	0	0	0	0	1	octet 1

And where *musim-GapPreferenceList* IE #n is:

8	7	6	5	4	3	2	1	bit no.
A9	A8	A7	A6	A5	A4	A3	A2	octet 1
A1	A0	B3	B2	B1	B0	Reserved		octet 2
C2	C1	C0	D3	D2	D1	D0	Reserved	octet 3
E13	E12	E11	E10	E9	E8	E7	E6	octet 4
E5	E4	E3	E2	E1	E0	Reserved		octet 5

A9..A0 = 0..1023 Indicates gap starting SFN number for the aperiodic MUSIM gap preference (binary coded, A9 is most significant bit and A0 least significant bit).

B3..B0 = 0..9 Indicates gap starting subframe number for the aperiodic MUSIM gap(binary coded, B3 is most significant bit and B0 least significant bit).

C2..C0 = 0..4 Indicates the length of the UE's MUSIM gap as specified in TS 38.133 [14] clause 9.1.10. This field is mandatory present for both periodic gap and aperiodic gap preference indication (binary coded, C2 is most significant bit and C0 least significant bit).

C2..C0 = 0; ms3.

C2..C0 = 1; ms4.

C2..C0 = 2; ms6.

C2..C0 = 3; ms10.

C2..C0 = 4; ms20.

D3..D0 = 0..8 Indicates the gap repetition period in ms for the periodic MUSIM gap as specified in TS 38.133 [14] clause 9.1.10 (binary coded, D3 is most significant bit and D0 least significant bit).

D3..D0 = 0; ms20.

D3..D0 = 1; ms40.

D3..D0 = 2; ms80.

D3..D0 = 3; ms160.

D3..D0 = 4; ms320.

D3..D0 = 5; ms640.

D3..D0 = 6; ms1280.

D3..D0 = 7; ms2560.

D3..D0 = 8; ms5120.

E13..E0= 0.. (gap repetition period-1) Indicates the gap offset in number of subframes for the periodic MUSIM gap as specified in TS 38.133 [14] clause 9.1.10. This field is mandatory present for the periodic MUSIM gap indication (binary coded, E13 is most significant bit and E0 least significant bit).

6.13.2 SET MUSIM UAI RESPONSE

This message is only sent in the direction UE to SS.

Information Element	Reference	Presence	Format	Length
Protocol discriminator	TS 24.007 [5], sub clause 11.2.3.1.1	M	V	½
Skip indicator	TS 24.007 [5], sub clause 11.2.3.1.2	M	V	½
Message type		M	V	1

where message type is:

8	7	6	5	4	3	2	1	bit no.
1	0	1	1	0	0	1	1	octet 1

7 Variables, constants and timers

7.1 State variables

Same as [9] TS 36.509, subclause 7.1 except:

STCH_PACKET_COUNTER(SL_ID)

This 32-bit integer state variable is used to count successful reception of SDAP SDUs while UE test loop mode E is activated and TEST_LOOP_MODE_E_TRIGGER is set to RECEIVE. The counter variable is indexed with SL_ID = 0...(MAX_ModeE_Monitor_Entities). STCH_PACKET_COUNTER(SL_ID) shall be set to zero when UE is switched on. If configured value of variable PROSE_COMMUNICATION_MONITOR_N is set to 0 then UE counts all SDAP SDUs as part of one counter STCH_PACKET_COUNTER(0) irrespective of Group Destination IDs or Destination Layer-2 IDs.

7.2 Constants

Same as [9] TS 36.509, subclause 7.2.

7.3 Timers

Same as [9] TS 36.509, subclause 7.3.

7.4 Configurable parameters

Same as [9] TS 36.509, subclause 7.4.

8 Electrical Man Machine Interface (EMMI)

The EMMI is used for automation of conformance testing. The commands used on the EMMI by the System Simulator, shall be limited to those specified in TS 38.523-3 [3]. An illustration is given in figure 8-1 as an example.

At the System Simulator side, the logical EMMI using mandatory AT commands shall interface with the Main Test Component (MTC) of TTCN test cases which hosts the Upper Tester. The physical EMMI interface towards the UE may be for example a standard USB interface. Other interfaces of proprietary or standardized type shall not be precluded.

At the UE side an adapter needs to be provided by the UE manufacturer for converting the commands into the UE manufacturer specific interface and format.

The use of EMMI is optional for the UE.

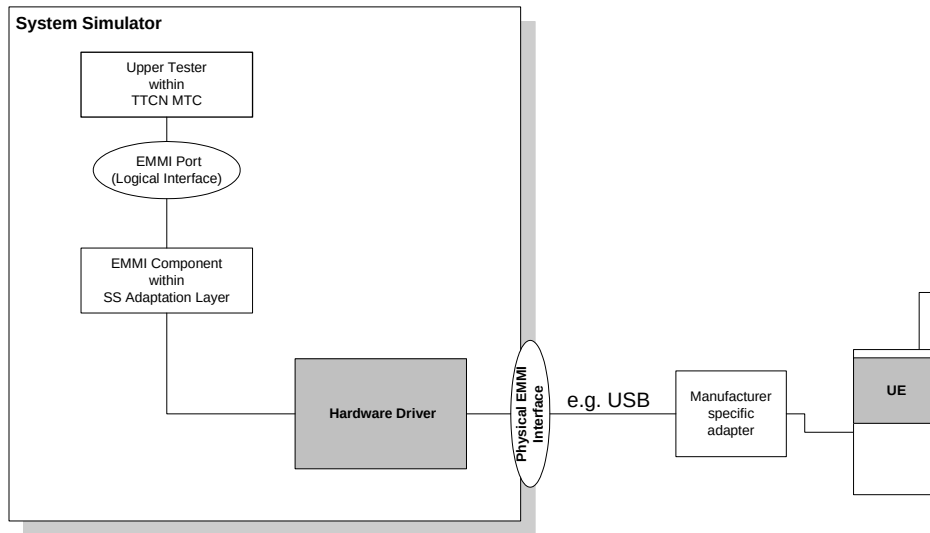

Figure 8-1: An example of EMMI and its use for automation of signalling testing

Annex A (normative): Pre-defined message containers used for testing

A.1 Predefined UE Capability container

NOTE: For sake of testability, the below container list does not describe the true capability of the UE and does not rely on UEs support of EN-DC.

ue-CapabilityRAT-ContainerList

```
{
  {
    rat-Type nr,

    ue-CapabilityRAT-Container '
E9A29800575F5A935F0A03C32001609317941BCBD09009B20C39F30C7942C0E0D8040623805D46C28C0D608C
21A08107482407D6C98AB1A1CF88E3D033EC09F1991C790E7D033EC09F51CF9863CA16070387938002F800E0
00BE00088000E0551B137582308682041D20901F5B262AC6873E238F40CFB027C66471E439F40CFB027D473E61
8F28581C0E1E4E000BE0038002F800224003800D940001400001506C00D608C21A08107882405D6C98AB091C79
0E7C62471E439F51CF9863CA16070387827F7000001FDC00000110001C00408385000000061E140006134000208C
38280389A0000081587800001C4D000006120400C028809A1A00BC090226C73E1C29D3B639F0E14E9DB1CF870
A74ED8E7C37A09801F00140E0A00E0601280380030120020301F03C01000000008000010040000100200000C0100
0802008020000100100000A0080000600400003802001000000040020300C0080000800400004802000028010000160
080000C0339535953582B5829583359335819583B580B581B5809594B581140C04000025949410000196525040000
A594901000039652427000104B292028000B2CA480800034B292020000F2CA480800044B29202000132CA4808000
54B29282000172CA480800064B292018A55574AAA82C552A8BA551541A2A93455038AA0F154062A93555298
AA05142405201F40A05028140A05028140A05028140A05028000300080A0041010020140400800080801000020040
104040300601002014728840004080C10181C282C30344044484C5060646C70747C8494989CA0A4A8B4BCD10519
0'H

  },
  {
    rat-Type eutra-nr,

    ue-CapabilityRAT-Container
'A107A04908360000808109870A00000011102C1C038500000048A824020C0C0385000000808B91504C040101870
A000001811722A0900030200E14000002021C88C268C01C28000C2680010881309A08070A000309A000522068260
000808385000000C08722205811170A00000311184C2C0385000184D000211026130400E1400061340008440902C9
C0385000001C888164C45C2800000C406130100E140006134000A440D0480818D8070A000004010E454130200436
1C2800001204391102C640385000004888163001C280000E4441A0004040C4C0385000002888834000C08010987
0A000005911068041169B4100E1400000C2220D808022D34821C2800001A4441A0104020D0403850000038888360
200804120870A000007911048049A08070A00000811104C048920870A00000891184D180305007134000091102613
4100C1401C4D000026440984C2C03050071340000911026130400C1401C4D000024440984C0403050071340000991
0241311004505C4D0000284441A000604008A0B89A000054888360000808114171340000B11108800101020626360
1C4D00002E444220006040081890D871340000C11108C000101020624361C4D00003244422000404481818D807134
0000D111088001011306004361C4D000036444230000404481810D871340000E11506800105031100E2680001D021
C8A834000C280108871340000F010E4541B00004140844389A00007C08722A0900830B00E26800008022E4441B00
004044818B89A00008089C5404081818D8021F0E0000061340042102205C56040081810D821F0E000006134004410
2205C440C0C6C010F8700000309A0023081102E220206360087C380000184D0012040881711810021B043E1C0000
0C268009420440B8A80810303130043E1C00000C268008420440B8AC0801030213043E1C00000C268008820440B8
88181898021F0E0000061340046102205C44040C4C010F8700000309A0024081102E230200426087C380000184D00
12840881715010206060E0087C380000184D00108408817158100206040E087C380000184D00110408817110303070
043E1C00000C268008C20440B888081838021F0E0000061340048102205C46040081C10F8700000309A0025081102
E23020040C087C380000184D001304088170D810021F0E000006134004E102205C4404081818D80700000309A002
8081102E2202060C0086C380000184D0014840881711810020604361C00000C268009820440F8680018D807000003
09A002A021C20440F88808103031300E0000061340050043840881F11010306004261C00000C26800A4087081103E
```

23020040C084C380000184D0013010E102207C54040818103030700E0000061340056043840881F150103060040C08
1C380000184D0016010E102207C56040081810302070E0000061340044043840881715000206040C0C1C038000018
4D00158408817150003060040C081C380000184D0016040881F11030206060E01C00000C26800B4087081103E2306
0040C081C380000184D0013010E102207C54040808103030700E0000061340056043840881F15010202060C0081C3
80000184D0010810E102207C56040080810302070E0000061340044043840881F15000202040C0C1C0380000184D0
015810E102207C54000808183002070E0000061340042043840881F150003020040C081C380000184D0016010E1022
07C4404081818380700000309A0028022E102207C44040C1801038700000309A0029022E102207C46040081810387
00000309A0026022E102207C4400081818380700000309A0028021C20440F88800183002070E000006134005204384
088171500020204040C1C0380000184D001584088171500030200404081C380000184D0016040881F11010202060E0
1C00000C26800B4087081103E230200404081C380000184D0013010E102207C4400080818380700000309A0028023
F081103E220006040081C380000184D0014811F840881F15010202060C00818380000184D0010810E102207C56040
080810302060E0000061340044043840881F15000202060C00818380000184D0010810E102207C54000C0801030206
0E0000061340058043840881F110103060040C1C00000C26800B8087081103E23020040C0818380000184D0013010
E102207C44000C1801030700000309A002E021C20440F86C1801030700000309A0027023F081102E2A0004040808
18300700000309A002B081102E2A000604008081030700000309A002C081103E220204040C180380000184D001781
0E102207C4604008081030700000309A0030021C20440F88800101030600E0000061340062043840881F1100030200
40C1C00000C26800B8087081103E1A02260C45C00000C26800C8087081103E1B022240C5C00000C26800CC0870
81103E1A02060C45C00000C26800D0087081103E1B020040C5C00000C26800D4087081102E1A02260C01C00000
C26800D820440B86C0889030700000309A0037081103E1A02060C01C00000C26800E0087081103E1B020040C1C0
0000C268009C087081103E1A00060C01C00000C26800E0087081103E130622E0000061340072045C20440B888001
81002020E000006134005C102207C360400808380000184D00138117081102E130222E000006134007210220482600
00800389A00000C8A8160041C4D00007404391504C080113870000001D810E4442202040C0C6C010F870000001E1
1108C080103021B043E1C0000007A4442202040C0C4C010F870000001E11108C0801030213043E1C0000007A4442
202040C0C1C010F870000001E11108C0801030207043E1C0000007A44413022043E1C0000007C4441A02060C0086
C38000000FC88834044818989807000002011106808983112130E000000412220D811120624261C000000844441A0
2040C4C4C0380000010C88834040C18890987000002211106C08010312130E0000004522A15010202040C0818183
80700000023010E4542A0204040C18010302070E00000047021C8A85604008081030206040E1C0000009004391188
8001030206060E01C0000009244098880018300206040E1C00000094440D888001010206060E01C000000920439103
6220004040C1801038700000025810E440D8880018100206040E1C00000094043910241A02240C0C1C03800000130
88834044C180103870000002691106C08890302070E0000004E2231100020204040C1C038000001248813110003020
0404081C380000012888131500020204040C1801030700000027910262A0006040080810302060E0000005022068240
44C188B80000014408722A0981112062E00000052021C888168245C4D00000C44413060045A9C4D0000A6444220
004040CA00114871340002A11106C08011412292E268000202220D800022824525C4D0000404441211065045C4D0
000AA4441A0004040CA08B89A000158888340008081940071340002B911048001941171340002C11504800194007
1340002C810E4440B0C00E2680005A2221100820604820D180389A00016C888440208181A0802460E2680005C222
11008306004820918389A00017488846020081812082460E2680005E2221100820104820D180389A00016C88844020
8041A0802460E2680005C22211808020104820918389A00017888844020804103034600E2680005B22211008201060
C00918389A00017088846020080410302460E2680005E22215008206040C0D040120871340002F9110A8041830020
604820904389A000180888560200818103024104821C4D0000C2442201040C4D04012087134000311110880418311
24104821C4D0000C644423010040C490412087134000321110A804100820604160D040389A0001948885402080418
30020B04821C4D0000CC4442B0100402081810582410E268000672221100820104080D040389A0001A0888440208
04182002410E2680006922211808020104080904389A0001A88884404086C194112292E2680006B2221101031B0045
048A4B89A0001B088846040086C11412292E2680006D222110003020045048A4B89A0001B8888460000808114122
92E2680006F222110002020636008A4B89A0001C088844000C08010D82292E26800071222118000202043608A4B8
9A0001C88884400084818A002292E26800073222110003120042808A4B89A0001D088846000084810A02292E2680
0075222110002020628008A4B89A0001C088844000C08010A02292E26800071222118000202042808A4B89A0001C
888844000808189002292E26800070222110003020042408A4B89A0001C488846000080810902292E268000722211
0002020622008A4B89A0001C088844000C08010882292E26800071222118000202042208A4B89A0001C888834000
C0801149F1340003B11106C00010102293E268000772220981002294E268000782220980002294E268000782221103
021B064E0089C389A0001E4888440C0C6C011382270E2680007A22211830021B044E089C389A0001EC888440408
6C193802270E268000792221101031B0044E089C389A0001E888846040086C11382270E2680007B2221100021B064
E0089C389A0001E488844000C6C011382270E2680007A22211800021B044E089C389A0001EC88844040C1801138
2270E2680007C222118100206044E089C389A0001F488844000C08011382270E2680007C222118000202044E089C3
89A0001F48884404081810D832722E2680007E2221101020606360089CB89A0001C088844040C18010D82272E268
000712221181002060436089CB89A0001C88884400080810D832722E2680007E2221100020206360089CB89A0001
C088844000C08010D82272E268000712221180002020436089CB89A0001C88883404086C1939971340003F9110680
818D802273E268000802220D810021B044E7C4D0001024441206064E85C4D00010444413060044E9C4D0000F044
422000404084C192807134000341110880010103130044A1C4D0000D244220006040084C112871340004191108C0
001010213044A1C4D0000D4442A00040408181898021F0E26800084222150003020040C084C10F87134000429110
AC00010102060426087C389A000218888440408181898021F0E268000692221181002060426087C389A0001A88884
40008181898021F0E268000692221180002060426087C389A0001A888836044481810F87134000439110680C103031

080401020100001000100400008000C0300680600C0600400400800180008020002000080600C020040010080400004
0004010000400020080401008180600D00C0180C0080080100040200800020001008020080408020000400060180340
300603002002004000C0004000000804040300601002000A00010000004000001000000402020180300801000500008
0000020100008000002000100C0180400800200008000001000000402020180300801000404008000200002000401004
01008020104008000100004000500C01A01803403006050020020040040080020100400010000802000040004020080
2010300C01A018030180100100200080801008040100402080200002000040008010000200008000A01803403006806
00C0A0040040080080100040400800020000200040080001000040004010040100802010500C01A018034030060500
200200400400800180010000004010080600C02004000C0008020002000040300601002000600020000010040201803
00801000300010040008000100C0180400800180010000002008080600C02004000C000802000100004030060100200
0600020000008020201803008010002000180804030060100200020003008080100A200010040004000100C01880002
00000800000100800080002018031000040100010000002000001000040300610000C020002000080600C300010000
004010000800040300618000C0000080000040202018030C00060000040080002000100C018600030100020000010
0080600C30001000000600000080404030061800080000301000040002018030C00040100018000002000100C018
A000200000080000020000008000001008080600C5000100000040000010040004000000800040300620000800000100008060
000008000002000000400020180310000400000100000040000008040403006200008000002008000800000100008060
0C4000100000040000010040002000100C018600030000008000001008080600C300018000004010000800040300618
000C040002000000400020180314000400000100000040000010040004000100C018A00020000008020002000000800
0002000080600C200018000006020100C01840003010000C00020180308000401000380004008052000040000010000
004020001000080100A2000080000100201002014600010000004000004010080100A30400800010000400040100001
000020004008040200802010500201600402C00805100008000004010080100A2000100000040101002014200010080
80100A40001000000400000100000020101002014800020000008000002008000400020040290000400000100400040
0000080004008052000080200020000008000001000080100A500010000004000001000000401000100004008052800
080000020080008000002000000800020040294000401000100000040000010000004000100201480002000000C00000
20080008000200402900004000001808000400000100004008052000080200030000008000002000080100A50001000
000400000100000020000010040400805280008000002000000802000100000080002004029400040100010000004000
000800000400010020148000200000080000010000008020200402900004000001000000201000100004008052000080
200020000004000002000080100A4040100002000020004008000100002000401808040100602040200003000060005
00201600402C008052020080001000010002004020080401008200C0002000030002010000180003000280100B00201
6004029010040100802008041002000040000800100600010000180010080000C0001800140080580100B0020148040
200002000201004010081010000180008060000C000600402C008052010080200804080400004000404000060002018
0003000180100B002014800020000008000001008000C00020040290000400000100400020000018000400805200008
0200020000004000003000080100A40001000000200000080400060001002014800020000004020001000000C000200
4029000040100008000002000001800040080518000800000200800180002004028C0004010001000000C0001002014
400020080024000200402900004000000800000401000100004008052000080000010080008000002000080100A4000
100400020000010000004000100201480002000000802000200000080002004029000040100010000004000001000040
08052000080000020000004000003010080100A30001000000200000300804008051800080000010080018000200402
8C0004010000800000C0001002014400020000024040200402900004000001004000200000100004008052800080000
0200000080000010080004000200402940004000001004000400000080000020001002014A000200800080000020000
004000001000080100A300018080004000001000040080518000800000200000040202004028C000400000100400020
001002014600020080008000001000080100A4040100002000020004018000400006000402000030000600040080401
00802010500201600402C00805202008000100001000200C000200003000201002018040300820040000800001000280
100B00201600402901004000080000800100601010020180410080000C00018001002000040000800140080580100B0
02014808020080401004020803000080000C000804000060000C0008010000200004000A00402C0080580100A40001
00000040000018080002000100201480002000000C04000200000040002004028C000600000018080002000100201460
003010000C000001000080100A500010000004000001000000400000080404008052800080000020000008020002000
0004000200402940004000001004000400000100000020001002014A000200800080000020000008000001000080100
A5000100000060000010000002000000804040080528000800000300000080000010080004000200402940004000001
800000401000080000020001002014A0002000000C0400020000004000001000080100A500010040006000001000000
200000080004008052800080000020000004000002008000800020040294000400000100000020100010000004000100
2014A000200000080200010000008000002000080100A50001004000400000080000040000010000400805200008000
0020000008020002000080100A3000100000060000018080400805180008000003010000C00020040280'H

}
}

Annex B (informative): Change history

Change history							
Date	Meeting	TDoc	CR	R ev	Cat	Subject/Comment	New version
2017-08	RAN5#76	R5-174100	-	-	-	Introduction of TS 38.509.	0.0.1
2017-12	RAN5#77	R5-176853	-	-	-	Adding technical content: UE beamlock special conformance testing function	0.1.0
2018-03	RAN5#78	R5-181211	-	-	-	Text proposal to add UE test loop mode A and B for 5GS (TP 38.509)	0.2.0
2018-04	RAN5#78	R5-182071	-	-	-	Text proposal to add UE functional block diagram for UE test loop modes A and B	0.3.0
2018-04	RAN5#78	R5-182070	-	-	-	Update of 38.509 general sections	0.3.0
2018-04	RAN5#78	R5-182037	-	-	-	Text Proposal on SS-RSRPB UE reporting	0.3.0
2018-05	RAN5#79	R5-182423	-	-	-	Editorial updates to 38.509	1.0.0
2018-05	RAN5#79	R5-182354	-	-	-	Text proposal to add message type ID for UBF and SS-RSRP messages'	1.0.0
2018-05	RAN5#79	R5-183081	-	-	-	Text proposal to UE test loop modes A and B	1.0.0
2018-06	RAN#80	RP-181209	-	-	-	put under revision control as v13.0.0 with small editorial changes	15.0.0
2018-09	RAN#81	R5-185057	0001	1	F	Editorial updates to 38.509	15.1.0
2018-09	RAN#81	R5-185523	0003	1	F	FR2_UE_BeamlockMode_IE_38.509	15.1.0
2018-12	RAN#82	R5-186863	0007	-	F	Update of Test Control UE Beamlock Function messages	15.2.0
2018-12	RAN#82	R5-187113	0009	-	F	Correction of 5GC terminology	15.2.0
2018-12	RAN#82	R5-187684	0008	1	F	Addition of Test Loop for SDAP testing	15.2.0
2018-12	RAN#82	R5-187891	0011	1	F	FR2 UE RSRPB Function 38.509	15.2.0
2019-03	RAN#83	R5-191128	0013	-	F	Addition of information for RESET UE POSITIONING STORED INFORMATION message	15.3.0
2019-03	RAN#83	R5-191196	0014	-	F	Resolving FFS's	15.3.0
2019-06	RAN#84	R5-194785	0017	-	F	Correction of clause used for UE position message definitions	15.4.0
2019-06	RAN#84	R5-195334	0016	1	F	Addition of NSSAI Test Mode	15.4.0
2019-09	RAN#85	R5-197184	0018	1	B	Addition of NSSAI Test Mode	15.5.0
2019-09	RAN#85	R5-197306	0020	1	F	Update to 38.509 for SS-RSRPB report	15.5.0
2019-12	RAN#86	R5-199307	0021	1	F	Deactivate Beamlock upon RRC disconnected	15.6.0
2020-01	RAN#86	-	-	-	-	Removal of duplicated rows in table 6.5.2 SS-RSRPB REPORT RESPONSE	15.6.1
2020-03	RAN#87	R5-200904	0027	1	F	Editorial update of Beamlock deactivation	15.7.0
2020-03	RAN#87	R5-201124	0024	1	F	Correction to SS-RSRPB reporting	15.7.0
2020-03	RAN#87	R5-201207	0026	1	F	Correction to NSSAI DELETE REQUEST	15.7.0
2020-06	RAN#88	R5-202884	0030	1	F	CR to 38.509 to clarify UBF for Intra-Band Carrier Aggregation	15.8.0
2020-09	RAN#89	R5-204402	0031	1	F	TMC Integrity and Ciphering Protection	15.9.0
2021-03	RAN#91	R5-211675	0033	1	F	Clarification of DRB identity in CLOSE UE TEST LOOP message in 38.509	15.10.0
2021-03	RAN#91	R5-211549	0034	1	B	Addition of UAI test function	16.0.0
2021-06	RAN#92	R5-213421	0037	1	F	Update UE Positioning test mode procedures and UE Positioning messages	16.1.0
2021-06	RAN#92	R5-213568	0035	1	B	Addition of test mode for NR sidelink	16.1.0
2021-06	RAN#92	R5-213569	0036	1	F	Addition of ProSe Packet Counter value reporting procedure for NR sidelink	16.1.0
2021-06	RAN#92	R5-213582	0039	1	B	Addition of test function Set UL Message - NR	16.1.0
2021-06	RAN#92	R5-213880	0040	1	A	UE Beamlock Function update for MIMO	16.1.0
2021-09	RAN#93	R5-216069	0045	1	F	Update to UE test loop mode E to trigger SL-MIMO transmission	16.2.0
2021-09	RAN#93	R5-216275	0044	1	B	Addition of predefined UE capability container for test function Set UL Message - NR	16.2.0
2021-12	RAN#94	R5-217935	0047	1	B	Addition of NR positioning methods information in the RESET UE POSITIONING STORED INFORMATION message	16.3.0
2022-03	RAN#95	R5-221401	0058	-	F	Addition of EHC function to the test loop mode A	16.4.0
2022-03	RAN#95	R5-221410	0051	1	F	Editorial update of section 6.6.2 and 6.7	16.4.0
2022-03	RAN#95	R5-221430	0053	1	A	Addition of test loop mode for NE-DC	16.4.0
2022-03	RAN#95	R5-221516	0054	1	F	Correction to test loop procedures for SL test	16.4.0
2022-03	RAN#95	R5-221517	0055	1	F	Correction to test protocol messages for SL test	16.4.0
2022-03	RAN#95	-	-	-	-	upgraded to Rel-17 because of Rel-17 freeze	17.0.0
2022-09	RAN#97	R5-225331	0070	1	F	Add Loop back mode C related description for MBS	17.1.0
2022-09	RAN#97	R5-225611	0066	1	A	Rel-17 Extension of test control command message type values reserved for 5GS	17.1.0
2022-09	RAN#97	R5-225842	0068	1	A	Rel-17 Addition of new test function to limit Pcell power: Option 2	17.1.0
2022-12	RAN#98	R5-227514	0075	1	F	Update of Loop Mode C for MBS TC	17.2.0
2023-03	RAN#99	R5-231843	0078	1	A	Editorial on ACTIVATE POWER LIMIT REQUEST test function Rel-17	17.3.0
2023-06	RAN#100	R5-233380	0081	1	B	Addition of MUSIM UAI test function	17.4.0

