

**3rd Generation Partnership Project;
Technical Specification Group Radio Access Network (2019-12)**
3GPP TS 38.201 V16.0.0
NR;
Technical Specification
**Physical layer; General description
(Release 16)**



Keywords
3GPP, New Radio, Layer 1

3GPP

Postal address

3GPP support office address
650 Route des Lucioles - Sophia Antipolis
Valbonne - FRANCE
Tel.: +33 4 92 94 42 00 Fax: +33 4 93 65 47 16

Internet

<http://www.3gpp.org>

Copyright Notification

No part may be reproduced except as authorized by written permission.
The copyright and the foregoing restriction extend to reproduction in all media.

© 2019, 3GPP Organizational Partners (ARIB, ATIS, CCSA, ETSI, TSDSI, TTA, TTC).
All rights reserved.

UMTS™ is a Trade Mark of ETSI registered for the benefit of its members
3GPP™ is a Trade Mark of ETSI registered for the benefit of its Members and of the 3GPP Organizational Partners
LTE™ is a Trade Mark of ETSI registered for the benefit of its Members and of the 3GPP Organizational Partners
GSM® and the GSM logo are registered and owned by the GSM Association

Contents

Foreword.....	4
1 Scope.....	5
2 References.....	5
3 Definitions, symbols and abbreviations.....	5
3.1 Definitions.....	5
3.2 Symbols.....	5
3.3 Abbreviations.....	5
4 General description of layer 1.....	6
4.1 Relation to other layers.....	6
4.1.1 General protocol architecture.....	6
4.1.2 Service provided to higher layers.....	7
4.2 General description of layer 1.....	7
4.2.1 Multiple access.....	7
4.2.2 Physical channels and modulation.....	7
4.2.3 Channel coding.....	8
4.2.4 Physical layer procedures.....	8
4.2.5 Physical layer measurements.....	8
5 Document structure of physical layer specification.....	8
5.1 Overview.....	8
5.2 TS 38.201: Physical layer; General description.....	9
5.3 TS 38.202: Physical layer services provided by the physical layer.....	9
5.4 TS 38.211: Physical channels and modulation.....	9
5.5 TS 38.212: Multiplexing and channel coding.....	10
5.6 TS 38.213: Physical layer procedures for control.....	10
5.7 TS 38.214: Physical layer procedures for data.....	10
5.8 TS 38.215: Physical layer measurements.....	10
5.9 TS 37.213: Physical layer procedures for shared spectrum channel access.....	10
Annex A (informative): Preferred mathematical notations.....	12
Annex B (informative): Change history.....	13

Foreword

This Technical Specification has been produced by the 3rd Generation Partnership Project (3GPP).

The contents of the present document are subject to continuing work within the TSG and may change following formal TSG approval. Should the TSG modify the contents of the present document, it will be re-released by the TSG with an identifying change of release date and an increase in version number as follows:

Version x.y.z

where:

- x the first digit:
 - 1 presented to TSG for information;
 - 2 presented to TSG for approval;
 - 3 or greater indicates TSG approved document under change control.
- y the second digit is incremented for all changes of substance, i.e. technical enhancements, corrections, updates, etc.
- z the third digit is incremented when editorial only changes have been incorporated in the document.

1 Scope

The present document provides a general description of the physical layer of NR radio interface. The present document also describes the document structure of the 3GPP physical layer specifications, i.e. TS 38.200 series.

2 References

The following documents contain provisions which, through reference in this text, constitute provisions of the present document.

- [1] 3GPP TR 21.905: "Vocabulary for 3GPP Specifications"
- [2] 3GPP TS 38.202: "NR; Services provided by the physical layer"
- [3] 3GPP TS 38.211: "NR; Physical channels and modulation"
- [4] 3GPP TS 38.212: "NR; Multiplexing and channel coding"
- [5] 3GPP TS 38.213: "NR; Physical layer procedures for control"
- [6] 3GPP TS 38.214: "NR; Physical layer procedures for data"
- [7] 3GPP TS 38.215: "NR; Physical layer measurements"

3 Definitions, symbols and abbreviations

3.1 Definitions

For the purposes of the present document, the terms and definitions given in TR 21.905 [1] and the following apply. A term defined in the present document takes precedence over the definition of the same term, if any, in TR 21.905 [1].

Definition format

<defined term>: <definition>.

example: text used to clarify abstract rules by applying them literally.

3.2 Symbols

For the purposes of the present document, the following symbols apply:

Symbol format

<symbol> <Explanation>

3.3 Abbreviations

For the purposes of the present document, the abbreviations given in TR 21.905 [1] and the following apply. An abbreviation defined in the present document takes precedence over the definition of the same abbreviation, if any, in TR 21.905 [1].

BPSK	Binary Phase Shift Keying
CP	Cyclic Prefix
DFT-s-OFDM	Discrete Fourier Transform-spread-Orthogonal Frequency Division Multiplexing
DU	Distributed Unit

E-UTRA	Evolved Universal Terrestrial Radio Access
FDD	Frequency Division Duplex
FEC	Forward Error Correction
HARQ	Hybrid Automatic Repeat Request
IAB	Integrated access and backhaul
LDPC	Low Density Parity Check
MAC	Medium Access Control
MIMO	Multiple Input Multiple Output
MT	Mobile Termination
OFDM	Orthogonal Frequency Division Multiplexing
PBCH	Physical Broadcast Channel
PDCCH	Physical Downlink Control Channel
PDSCH	Physical Downlink Shared Channel
PRACH	Physical Random Access Channel
PSBCH	Physical Sidelink Broadcast Channel
PSCCH	Physical Sidelink Control Channel
PSFCH	Physical Sidelink Feedback Channel
PSSCH	Physical Sidelink Shared Channel
PUCCH	Physical Uplink Control Channel
PUSCH	Physical Uplink Shared Channel
QAM	Quadrature Amplitude Modulation
QPSK	Quadrature Phase Shift Keying
RLC	Radio Link Control
RRC	Radio Resource Control
SAP	Service Access Point
SRS	Sounding reference signal
TDD	Time Division Duplex
UE	User Equipment

4 General description of layer 1

4.1 Relation to other layers

4.1.1 General protocol architecture

The radio interface described in this specification covers the interface between the User Equipment (UE) and gNB, between gNBs, between IAB-node DU and IAB-node MT/UE, and between UEs. The radio interface is composed of the Layer 1, 2 and 3. The TS 38.200 series describes the Layer 1 (Physical Layer) specifications. Layers 2 and 3 are described in the 38.300 series.

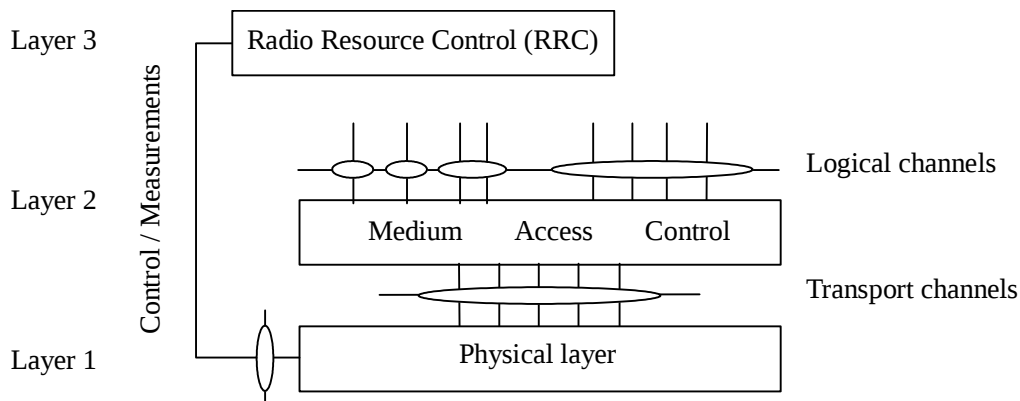

Figure 1: Radio interface protocol architecture around the physical layer

Figure 1 shows the NR radio interface protocol architecture around the physical layer (Layer 1). The physical layer interfaces the Medium Access Control (MAC) sub-layer of Layer 2 and the Radio Resource Control (RRC) Layer of

Layer 3. The circles between different layer/sub-layers indicate Service Access Points (SAPs). The physical layer offers a transport channel to MAC. The transport channel is characterized by how the information is transferred over the radio interface. MAC offers different logical channels to the Radio Link Control (RLC) sub-layer of Layer 2. A logical channel is characterized by the type of information transferred.

4.1.2 Service provided to higher layers

The physical layer offers data transport services to higher layers. The access to these services is through the use of a transport channel via the MAC sub-layer. Details are specified in [2].

4.2 General description of layer 1

4.2.1 Multiple access

The multiple access scheme for the NR physical layer is based on Orthogonal Frequency Division Multiplexing (OFDM) with a cyclic prefix (CP). For uplink, Discrete Fourier Transform-spread-OFDM (DFT-s-OFDM) with a CP is also supported. To support transmission in paired and unpaired spectrum, both Frequency Division Duplex (FDD) and Time Division Duplex (TDD) are enabled.

The Layer 1 is defined in a bandwidth agnostic way based on resource blocks, allowing the NR Layer 1 to adapt to various spectrum allocations. A resource block spans 12 sub-carriers with a given sub-carrier spacing.

The radio frame has a duration of 10ms and consists of 10 sub-frames with a sub-frame duration of 1ms. A sub-frame is formed by one or multiple adjacent slots, each having 14 adjacent symbols. Further details on the frame structure are specified in [2].

4.2.2 Physical channels and modulation

The physical channels defined in the downlink are:

- the Physical Downlink Shared Channel (PDSCH),
- the Physical Downlink Control Channel (PDCCH),
- the Physical Broadcast Channel (PBCH),

The physical channels defined in the uplink are:

- the Physical Random Access Channel (PRACH),
- the Physical Uplink Shared Channel (PUSCH),
- and the Physical Uplink Control Channel (PUCCH).

The physical channels defined in the sidelink are:

- the Physical Sidelink Broadcast Channel (PSBCH),
- the Physical Sidelink Control Channel (PSCCH),
- the Physical Sidelink Feedback Channel (PSFCH),
- and the Physical Sidelink Shared Channel (PSSCH).

In addition, signals are defined as reference signals, primary and secondary synchronization signals.

The modulation schemes supported are

- in the downlink, QPSK, 16QAM, 64QAM, and 256QAM,
- in the uplink, QPSK, 16QAM, 64QAM and 256QAM for OFDM with a CP and $\pi/2$ -BPSK, QPSK, 16QAM, 64QAM and 256QAM for DFT-s-OFDM with a CP

4.2.3 Channel coding

The channel coding scheme for transport blocks is quasi-cyclic LDPC codes with 2 base graphs and 8 sets of parity check matrices for each base graph, respectively. One base graph is used for code blocks larger than certain sizes or with initial transmission code rate higher than thresholds; otherwise, the other base graph is used. Before the LDPC coding, for large transport blocks, the transport block is segmented into multiple code blocks with equal size. The channel coding scheme for PBCH and control information is Polar coding based on nested sequences. Puncturing, shortening and repetition are used for rate matching. Further details of channel coding schemes are specified in [4].

4.2.4 Physical layer procedures

There are several Physical layer procedures involved. Such procedures covered by the physical layer are;

- Cell search
- Power control
- Uplink synchronisation and Uplink timing control
- Random access related procedures
- HARQ related procedures
- Beam management and CSI related procedures
- Sidelink related procedures
- Channel access procedures

Through the control of physical layer resources in the frequency domain as well as in the time and power domains, implicit support of interference coordination is provided in NR.

4.2.5 Physical layer measurements

Radio characteristics are measured by the UE and the network and reported to higher layers. These include, e.g. measurements for intra- and inter-frequency handover, inter RAT handover, timing measurements, and measurements for RRM.

Measurements for inter-RAT handover are defined in support of handover to E-UTRA.

5 Document structure of physical layer specification

5.1 Overview

The physical layer specification consists of a general document (TS 38.201), and seven documents (TS 38.202, 38.211 through 38.215, and 37.213). The relation between the physical layer specifications in the context of the higher layers is shown in Figure 2.

To/From Higher Layers

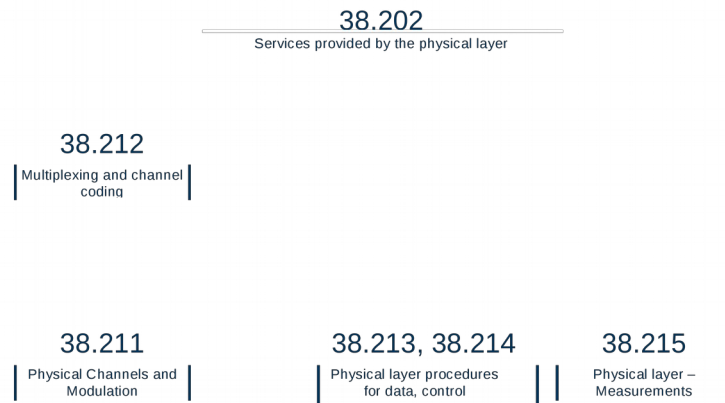

Figure 2: Relation between Physical Layer specifications

5.2 TS 38.201: Physical layer; General description

The scope is to describe:

- The contents of the Layer 1 documents (TS 38.200 series);
- Where to find information;

5.3 TS 38.202: Physical layer services provided by the physical layer

The scope is to describe services provided by the physical layer, and to specify:

- Services and functions of the physical layer;
- Model of physical layer of the UE;
- Parallel transmission of simultaneous physical channels and SRS;
- Measurements provided by the physical layer.

5.4 TS 38.211: Physical channels and modulation

The scope is to establish the characteristics of the Layer-1 physical channels, generation of physical layer signals and modulation, and to specify:

- Definition of the uplink, downlink and sidelink physical channels;
- Frame structure and physical resources;
- Modulation mapping (BPSK, QPSK, etc);
- OFDM signal generation;
- Scrambling, modulation and upconversion;
- Layer mapping and precoding;
- Physical shared channel in uplink, downlink and sidelink;
- Reference signal in uplink, downlink and sidelink;

- Physical random access channel;
- Primary and secondary synchronization signals.

5.5 TS 38.212: Multiplexing and channel coding

The scope is to describe the transport channel and control channel data processing, including multiplexing, channel coding and interleaving, and to specify:

- Channel coding schemes;
- Rate matching;
- Uplink transport channels and control information;
- Downlink transport channels and control information;
- Sidelink transport channels and control information.

5.6 TS 38.213: Physical layer procedures for control

The scope is to establish the characteristics of the physical layer procedures for control, and to specify:

- Synchronization procedures;
- Uplink power control;
- Random access procedure;
- UE procedure for reporting control information;
- UE procedure for receiving control information.

5.7 TS 38.214: Physical layer procedures for data

The scope is to establish the characteristics of the physical layer procedures for data, and to specify:

- Power control;
- Physical downlink shared channel related procedures;
- Physical uplink shared channel related procedure;
- Physical sidelink shared channel related procedure.

5.8 TS 38.215: Physical layer measurements

The scope is to establish the characteristics of the physical layer measurements, and to specify:

- Control of UE/NG-RAN measurements;
- Measurement capabilities for NR.

5.9 TS 37.213: Physical layer procedures for shared spectrum channel access

The scope is to establish the characteristics of the physical layer procedures for shared spectrum channel, and to specify:

- Downlink channel access procedures;

- Uplink channel access procedures.

Annex A (informative): Preferred mathematical notations

The following table contains the preferred mathematical notations used in L1 documentation.

item	notation
multiply product	cross sign, e.g. $a \times b$
matrix product	dot sign, e.g. $a \cdot b$
scalar product (product of a matrix by a scalar)	dot sign, scalar should precede matrix e.g. $(1 + j) \begin{bmatrix} u \\ v \end{bmatrix}$
matrix dimensioning	number of rows \times number of column, e.g.: $R \times C$
Kronecker product	$a \otimes b$
bracketing of sets (all elements of same type, not ordered elements)	curly brackets $\{\}$, e.g. $\{a_1, a_2, \dots, a_p\}$, or $\{a_i\}_{i \in \{1, 2, \dots, p\}}$
bracketing of lists (all elements not necessary of same type, ordered elements)	round brackets $()$, e.g. (A, u, x)
bracketing of sequences (all elements of same type, ordered elements)	angle brackets, e.g. $\langle a_1, a_2, \dots, a_p \rangle$ or $\langle a_i \rangle_{i \in \{1, 2, \dots, p\}}$
bracketing of function argument	round brackets, e.g. $f(x)$
bracketing of array index	square brackets, e.g. $a[x]$
bracketing of matrix or vector	square brackets $[\]$, e.g. $\begin{bmatrix} x \\ y \end{bmatrix}$, $\begin{bmatrix} x & y \end{bmatrix}$, or $\begin{bmatrix} 1 & 1 \\ 1 & -1 \end{bmatrix}$
Separation of indexes	use a comma : e.g. $N_{i,j}$
use of italic for symbols	a symbol should be either in italic or in normal font, but mixing up should be avoided.
bracketing of arithmetic expression to force precedence of operations	round brackets : e.g. $(a + b) \times c$
necessity of bracketing arithmetic expressions	When only $+$ and \times bracketing is not necessary. When the mod operator is used explicit bracketing of mod operands and possibly result should be done.
number type	in a context of non negative integer numbers, some notes should stress when a number is signed, or possibly fractional.
binary xor and and	respectively use $+$ or \cdot . If no "mod 2" is explicitly in the expression some text should stress that the operation is modulo 2.
matrix or vector transpose	v^T
1x1 matrices	implicitly cast to its unique element.
vector dot product	$u^T \cdot v$ for column vectors, and $u \cdot v^T$ for line vectors
complex conjugate	v^*
matrix or vector Hermitian transpose	v^H
real part and imaginary part of complex numbers.	$\text{Re}(x)$ and $\text{Im}(x)$
Modulo operation (including negative value) $r \equiv a \pmod N$	Let Q be the integer quotient of a and N , Z is integer, r is remainder then $q \in Z$ $a = N \times q + r, \text{ where } q = \lfloor a / N \rfloor \text{ for all } a \text{ and } N$ $0 \leq r < N $ <p>(Note that $\lfloor \bullet \rfloor$ is floor operation to round the elements of \bullet to the nearest integers towards minus infinity)</p>

Annex B (informative): Change history

Change history							
Date	Meeting	TDoc	CR	Rev	Cat	Subject/Comment	New version
2017-05	RAN1#89	R1-1708435				Draft skeleton	0.0.0
2017-07	AH_1706	R1-1712012				Inclusion of agreements up to and including RAN1 NR Ad-Hoc #2	0.0.1
2017-08	RAN1#90	R1-1713894				Updates according to email discussion " [NRAH2-03-201] TS 38.201"	0.0.2
2017-08	RAN1#90	R1-1715069				Clean version	0.1.0
2017-08	RAN1#90	R1-1715319				Inclusion of agreements up to and including RAN1 #90	0.1.1
2017-09	RAN #77	RP-171998				For information to RAN	1.0.0
2017-11	RAN1#90b	R1-1719242				Inclusion of agreements up to and including RAN1#90bis	1.0.1
2017-11	RAN1#91	R1-1721046				Endorsed version by RAN1#90bis (email thread)	1.1.0
2017-12	RAN1#91	R1-1721339				Editorial update - Endorsed version by RAN1#91 (email thread)	1.2.0
2017-12	RAN#78	RP-172530				Endorsed version for approval by plenary.	2.0.0
2017-12	RAN#78					Approved by plenary – Rel-15 spec under change control	15.0.0
2019-12	RAN#86	RP-192661	0001	-	B	Introduction of V2X, NR-based access to unlicensed spectrum, integrated access backhaul for NR and remote interference management	16.0.0